

**K P M T O O O**

**Applies to the wide range of power measurements, from very low power to high power!!**



**Effective  
Jan.7.2013**

ErP Directive Lot 6 Requirements  
Second phase implementation  
Household electrical appliances  
and office electronic and electrical  
equipment

**Requires the standby  
power is reduced  
to **0.5 W**  
or less!**

**NEW**

## Digital Power Meter **KPM 1000**

Exclusively for single phase  
IEC62301 First Edition compliant, ErP Directive (Lot 6 and other) standby power measurements  
17 measurement items, including voltage, current, frequency, active power, phase angle, and power factor  
Basic accuracy  $\pm (0.1\% \text{ reading} + 0.1\% \text{ range})$   
Current range: 5 mA to 20 A  
RS232C standard interface  
GPIB/USB (factory option)

# From very low power to high power, applies to the wide range of power measurements!!

The KPM1000 Digital Power Meter is a single-phase power measuring instrument that applies to the wide range of power measurements, from very low power during standby mode to high power during operation mode. It has a minimum power range of 750 mW, with resolution of 0.01 mW, and the basic accuracy of 0.1% of reading with guaranteed accuracy extending from 1% of the range while it realizes a wide dynamic range.

In recent years, eco-design regulations have been actively implemented in many countries, starting with Europe's ErP Directive and including the United States' Energy Star and Japan's Top Runner Program. These regulations are being utilized by companies in their efforts to act against environmental problems and differentiate their products. Through ErP Directive Lot 6, the standby power (off mode and standby mode power consumption) of household electrical appliances and OA electronic equipment is regulated and the preparation of a declaration of conformity is required by CE marking. This requirement regulates the standby power to become 1 W or less; and starting in 2013, the regulation will be strictly reduced to 0.5 W or less. The KPM1000 can accurately measure the standby power even less than 0.5 W.

The KPM1000 complies with IEC62301 (the measurement of standby and off mode power in household and office electrical and electronic equipment products) standards, and it is capable to perform the standby power measurements required by ErP Directive Lot 6 and other regulations. System upgrades are also possible. Because of its size, weight, and various type of optional interface (some are factory options), the KPM1000 can be widely used as a bench-top instrument for measuring equipment power and also as a part of component of the test system.



**RS232C  
standard  
interface**  
GPIB/USB  
(factory option)

**NEW**

## Digital Power Meter **KPM1000**

**Effective  
Jan.7.2013**

ErP Directive Lot 6 Requirements  
Second phase implementation  
Household electrical appliances  
and office electronic and electrical  
equipment

**Requires the standby  
power is reduced  
to 0.5 W  
or less!**

# FUNCTION

# DIGITAL POWER METER KPM1000

## High-precision resolution

Voltage, current, and power basic accuracy  
± (0.1 % of reading + 0.1 % of range)

Voltage range	150V/300V/Auto range
Current range	5mA/10mA/20mA/50mA/100mA/200mA/500mA/1A/2A/5A/10A/20A/Auto range
Power range *	750mW/1.5W/3W/6W/7.5W/15W/15W/30W60W/75W/150W/300W/600W/750W/1.5kW/3kW/6kW *Automatically determined based on voltage/current range combination.

## Single-phase two-wire (measurement category: CAT II)

The measurement category is classified into several categories, such as CAT I, CAT II, CAT III, CAT IV, etc. The KPM1000 is capable of applying to the category CAT II measurement.

### [Measurement categories]

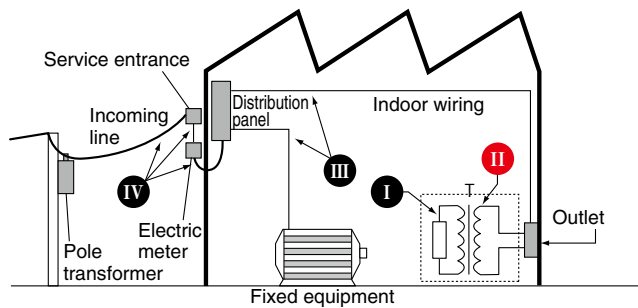

### [Maximum transient voltage]

Line-to-Neutral Voltage V r.m.s	Maximum Transient Voltage V peak		
	Measurement Category II*	Measurement Category III*	Measurement Category IV*
50	500	800	1500
100	800	1500	2500
150	1500	2500	4000
300	2500	4000	6000
600	4000	6000	8000
1000	6000	8000	12000

\*Measurement categories II, III, and IV apply only to measurements with the main power supply up to an AC effective value of 1000 V.

## Crest factor 6

Obtaining crest factor 6 realizes to perform high-precision measurements of waveforms having a small effective value but large peak value.

※ Allowable crestfactor of voltage measurement is 3.

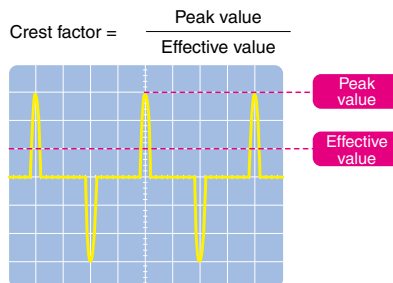

With the KPM1000:

$$\text{Crest factor} = \frac{(\text{measurement range} \times 6)}{\text{Measured value (effective value)}}$$

- ▶ Voltage (measurement range × 3)/measured value or 900 Vpk, whichever is less
- ▶ Current (measurement range × 6)/measured value or 120 Apk, whichever is less

## Four-item display

Displays four measurement items simultaneously. Save the trouble from switching the measurement item.

High visibility of seven-segment display provides excellent visibility even from distant positions.

## 17 diverse measurement items

- Voltage
- Current
- Active power
- Apparent power
- Reactive power
- Power factor
- Phase angle
- Frequency
- Integrated current
- Integrated power
- Integrated power in positive direction
- Integrated power in negative direction
- Integrated elapsed time
- Voltage crest factor
- Current crest factor
- Voltage peak
- Current peak

## Separate positive and negative measurements of cumulative power

The unit is suitable for measuring power consumption and regeneration of solar power conditioners and other system interconnection inverters.

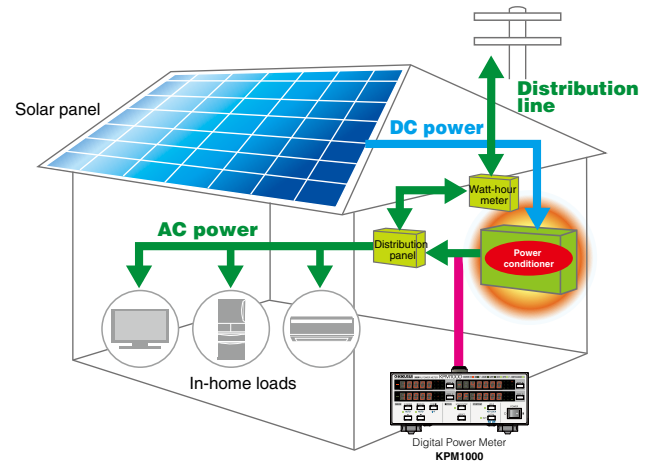

### [Example of display]

▼ Integrated elapsed time display

24h0000

▼ Integrated power (total) display [net power]

46.6665

▼ Integrated power (positive direction) display [purchased power]

P62.4352

▼ Integrated power (negative direction) display [sold power]

715.7687

## Simple operation

The KPM1000 can be operated intuitively without reliance on a manual.

## RS232C standard interface

\*GPIB, USB (factory option)

- Rear panel



# APPLICATION

## Power measurement and application examples

### ● Measurement with direct input (Less than 20A of DUT)

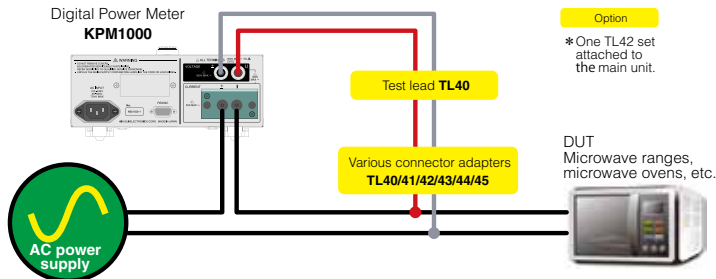

### ● Measurement using CT (current transformer) and PT (potential transformer) (Exceeds 20A of DUT)

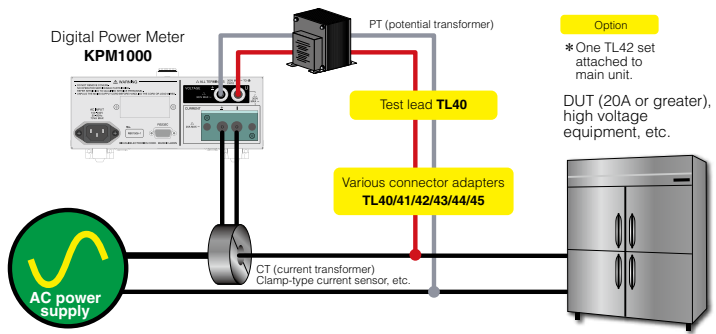

### Options



**Test lead [TL40]**  
Red/black One each  
1000V/ CAT II max 32A Length: 1m



**Safety plug (clamped connection type) [TL43]**  
Red/black One each  
600V/ CAT II max 10A



**Safety plug (threaded connection type) [TL41]**  
Red/black One each  
1000V/ CAT II max 32A



**Alligator clip [TL44]**  
Red/black One each  
1000V/ CAT II max 32A



**Safety plug (soldered connection type) [TL42]**  
Red/black One each  
1000V/ CAT II max 32A



**Fork terminal adapter [TL45]**  
Red/black One each  
1000V/ CAT II max 20A

## Utilization of Assist Tool

A handy application software Assist Tool can be downloaded from the WEB. It makes the operation possible from a PC as you would from the main unit panel. And as a data logger, it can easily acquire the long term periods of data, too.

### ● Collective display of measurement parameters

17 measurement items can be displayed in a single window.



**Free download from our Web site**

### ● Measurement data logging feature

Using the Assist Tool, you can import waveform data to the PC in the CSV format with a simple connection and a single press of a button. When an application such as Excel is used, graphs can easily be created.

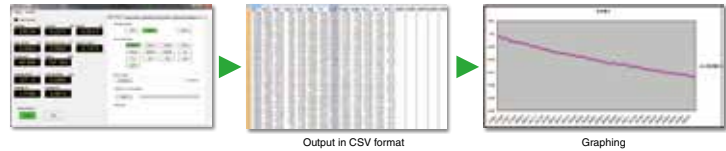

### ● Acquisition of voltage and current waveform data

You can easily import voltage and current waveforms to a PC. It is difficult to imagine what type of waveform they actually have even when the peak values, crest factors, and power factor values are viewed. Also, it is difficult to use and take measurements with an instrument such as an oscilloscope with linear measurements of surroundings. With this function, voltage and current waveform data can easily be imported to a PC in the CSV format. When an application such as Excel is used, graphs can easily be created.

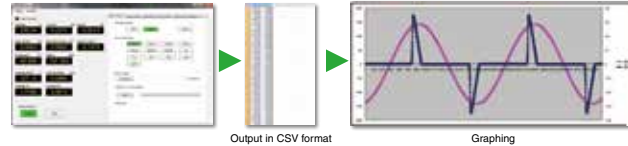

### ● Measurement of integrated power

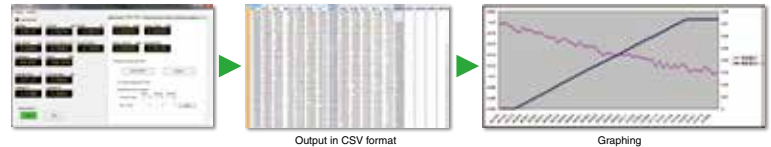

### ● Measurement of standby power

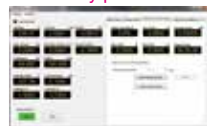

### ● Other, advanced settings



### ● Communication settings



## Power measurement and application examples

### Measurement of standby power

- Measurements complying with IEC62301 First Edition standards can be performed. It is possible to measure the “standby and off mode power” of the household and office electrical and electronic equipment products required by the standard such as ErP Directive Lot 6.

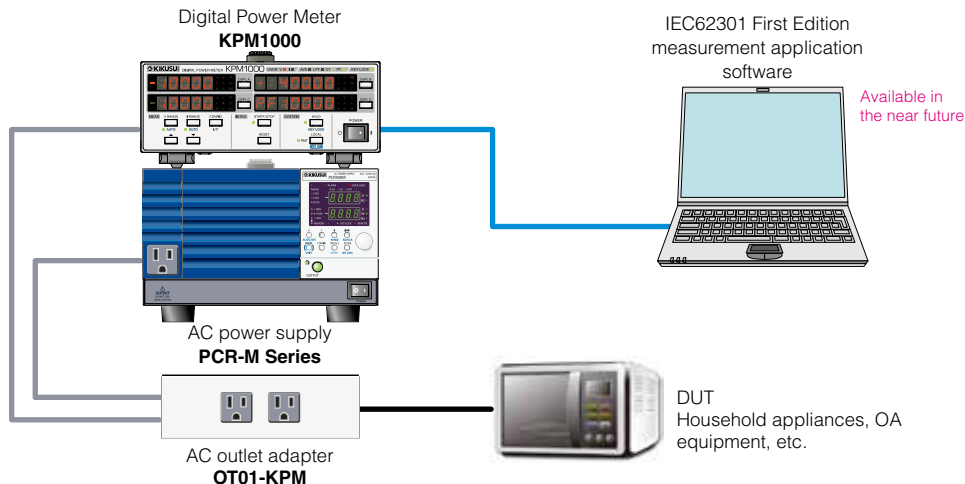

### 【What is the ErP Directive?】

The ErP Directive\* is a directive that requires ecodesigns (environmentally conscious designs) for energy-related products (ErP). An energy-related product is defined as “a product that does not directly consume energy but affects energy consumption in the stage of usage.” Therefore, the ErP Directive requires ecodesigns not only for electronic and electrical equipment and other products that directly consume energy but for products that indirectly affect energy consumption and reduction (such as windows and equipment that utilizes water). Specifically targeted products and requirements are determined by implementation measures (IMs) for each product field (lot). Environmentally compliant designs and limiting values for energy usage and energy efficiency are established particularly for the purpose of improving energy efficiency.

\* DIRECTIVE 2009/125/EC OF THE EUROPEAN PARLIAMENT AND OF THE COUNCIL of 21 October 2009 establishing a framework for the setting of ecodesign requirements for energy-related products

Power consumption of household electrical appliances and office electronic and electrical equipment in standby mode and off mode (Commission Regulation (EC) No 1275/2008)

Values prescribed by ErP Directive Lot 6

	Phase 1	Phase 2
Date of commencement for mandatory implementation of measure	7-Jan-10	7-Jan-13
Off mode power consumption	1 W or less	0.5 W or less
Standby mode power consumption	1 W or less (2 W or less when information or status is displayed)	0.5 W or less (1 W or less when information or status is displayed)

### Related options

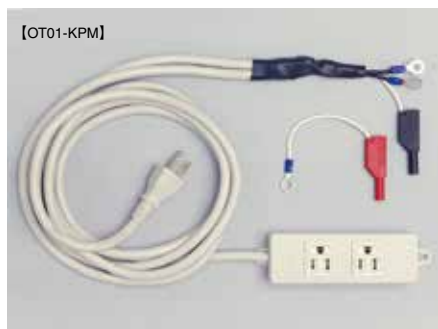

AC outlet cable  
[OT01-KPM]  
125V/15A



IEC62301 First Edition measurement application software  
[SD010-KPM] coming soon  
This is special application software for performing standard tests easily.

AC multi-outlet cable  
[OT02-KPM] coming soon  
250V/15A

# Specifications

Unless specified otherwise, the specification are for the following settings and conditions.

- The warm-up time is 30 minutes.
- After the KPM1000 has been warmed up, it must be calibrated correctly in a 23°C ± 5°C environment.

Input	
Measurement line	Single-phase two-wire (measurement category CAT II)*1
Voltage input terminal	Safety terminal
Current input terminal	M6 terminal block
Measurement rated voltage	300 Vrms
Measurement rated current	20 Arms
Maximum allowable input voltage	900 Vpk or 360 Vrms
Maximum allowable input current	120 Apk or 24 Arms
Maximum isolation voltage	300 V
Input impedance	Voltage input 6 M ± 10 % (50/60 Hz)
	Current input 2 m or less
Line filter (LPF)	Cutoff frequency 500 Hz (ON/OFF possible)

\*1 Applies to measurements on circuits directly connected to a low-voltage installation. This category applies to measurements on circuits of equipment on the primary side of a transformer. Such pieces of equipment have a power cord connected to a power outlet. Examples are household appliances and portable tools.

Display items	
Measurement items	Voltage, current, active power, apparent power, reactive power, power factor, phase angle, frequency, integrated current, integrated power, positive direction integrated power, negative direction integrated power, integrated time, voltage crest factor, current crest factor, voltage peak, current peak
Display update interval	100 ms / 200 ms / 500 ms / 1 s / 2 s / 5 s / 10 s
Number of display items	Four-item simultaneous display

Voltage measurement function				
Measurement range	Resolution	150 V	0.01 V	
		300 V	0.01 V	
Allowable crest factor		3		
Accuracy *1 *2	Effective input range	Full range	1% to 120% of range	
			45 Hz ≤ f ≤ 66Hz LPF:ON/OFF	± (0.1 % of reading + 0.1 % of range)
			66 Hz < f ≤ 400Hz LPF:OFF	± (0.1 % of reading + 0.2 % of range)
			400 Hz < f ≤ 1kHz LPF:OFF	± (0.1 % of reading + 0.2 % of range)
	1kHz < f ≤ 5kHz LPF:OFF		± (3 % of range)	
One-year accuracy (accuracy up to 12 months after calibration)		1.5 times the reading errors for the accuracy at 6 months		
Auto range	UP conditions	When the value exceeds 120 % of the range or when a peak over-range occurs		
	DOWN condition	When the value is less than 30 % of the range, the value is less than or equal to 90 % of the next lower range, and a peak overrange is not occurring		

\*1 Under the following conditions: within the effective input range, within six months after the last calibration, at a temperature of 23 °C ± 5 °C, sine wave, power factor of 1, and common mode voltage of 0 V. If the waveform is asymmetrical (waveforms such as half-wave rectified waveforms and full-wave rectified waveforms), errors will occur.

\*2 The peak voltage accuracy is defined for a sine wave whose frequency is between 45 Hz and 66 Hz. Accuracy: ± (0.1 % of reading + 3.1 % of range)

Current measurement function					
Measurement range	Resolution	5 mA	0.0001 mA		
		10 mA	0.001 mA		
		20 mA			
		50 mA			
		100 mA	0.01 mA		
		200 mA			
		500 mA			
				1 A	0.1 mA
				2 A	
				5 A	
		10 A			
		20 A	1 mA		
Allowable crest factor		6			
Accuracy *1 *2 *3	Effective input range	Full range	1% to 120% of range		
			45 Hz ≤ f ≤ 66Hz LPF:ON/OFF	± (0.1 % of reading + 0.1 % of range)	
			66 Hz < f ≤ 400Hz LPF:OFF	± (0.1 % of reading + 0.2 % of range)	
			400 Hz < f ≤ 1kHz LPF:OFF	± (0.1 % of reading + 0.2 % of range)	
	1kHz < f ≤ 5kHz LPF:OFF		± (3 % of range)		
Residual noise	Input short circuit LPF:ON/OFF	0.5 % of range			
One-year accuracy (accuracy up to 12 months after calibration)		1.5 times the reading errors for the accuracy at 6 months			
Auto range	UP condition	When the value exceeds 120 % of the range or when a peak over-range occurs			
	DOWN condition	When the value is less than 30 % of the range, the value is less than or equal to 90 % of the next lower range, and a peak overrange is not occurring			

\*1 Under the following conditions: within the effective input range, within six months after the last calibration, at a temperature of 23 °C ± 5 °C, sine wave, power factor of 1, and common mode voltage of 0 V.

If the waveform is asymmetrical (waveforms such as half-wave rectified waveforms and full-wave rectified waveforms), errors will occur.

\*2 When you are using the 5 mA range and the input is less than 10 % of the range, add (0.1 % of range).

\*3 The peak current accuracy is defined for a sine wave whose frequency is between 45 Hz and 66 Hz. Accuracy: ± (0.1 % of reading + 3.1 % of range)

Power measurement function					
Measurement range (combination of voltage range and current range)	Resolution	750 mW	0.01 mW		
		1.5 W	0.1 mW		
		3 W			
		6 W			
				7.5 W	1 mW
				15 W	
				30 W	
				60 W	
				75 W	0.01 W
				150 W	
		300 W			
		600 W			
		750 W	0.1 W		
		1.5 kW			
		3 kW			
		6 kW			
Accuracy *1 *2	Effective input range	Full range	1% to 144 % of range		
			45 Hz ≤ f ≤ 66Hz LPF:ON/OFF	± (0.1 % of reading + 0.1 % of range)	
			66 Hz < f ≤ 400Hz LPF:OFF	± (0.1 % of reading + 0.2 % of range)	
			400 Hz < f ≤ 1kHz LPF:OFF	± (0.1 % of reading + 0.3 % of range)	
	1kHz < f ≤ 3kHz LPF:OFF		± (3 % of range)		
Effect of power factor	Power factor 0	45Hz to 66Hz	±0.4% of VA		
	0 < Power factor < 1		Add (tan θ × 0.4)% of reading		
One-year accuracy (accuracy up to 12 months after calibration)		1.5 times the reading errors for the accuracy at 6 months			

\*1 Under the following conditions: within the effective input range, within six months after the last calibration, at a temperature of 23 °C ± 5 °C, sine wave, power factor of 1, and common mode voltage of 0 V.

If the waveform is asymmetrical (waveforms such as half-wave rectified waveforms and full-wave rectified waveforms), errors will occur.

\*2 When you are using the 5 mA range and the input is less than 10 % of the range, add (0.1 % of range).

# Specifications

# DIGITAL POWER METER KPM1000

Frequency measurement function	
Measurement range	10 Hz to 10 kHz
Measurement target	Voltage/current
Measurement input level	30% to 120% of measurement range
Frequency filter	ON (cutoff frequency 500 Hz)/OFF
Accuracy ±	(0.06 % of reading)

Math features	
Apparent power*1 *2	$VA = V \cdot A$
Reactive power*1 *2	$var = \sqrt{(VA)^2 - W^2}$
Power factor*1 *2	$PF = W / VA$
Phase angle*1 *2	$deg = \cos^{-1} (W / VA)$
Crest factor*1 *2	Peak value/effective value
Moving average (averaging)	OFF/ 2/ 4/ 8/ 16/ 32/ 64
Selectable range for the PT ratio	1 to 2000 in steps of 1
Selectable range for the CT ratio	1 to 2000 in steps of 1
Accuracy of leading phase and lagging phase detection	The voltage and current input is 50 % to 120 % of the measurement range. 45 Hz ≤ f ≤ 1 kHz LPF: Off ±10 °

\*1 This is determined through a digital computation using the voltage, current, and active power. For distorted signal input, the value obtained on the KPM1000 may differ from that obtained on other instruments that use a different method.

\*2 The measurement accuracy is determined by an expression whose components are the measurement accuracies of the voltage, current, and active power.

Integration feature		
Integration	Accuracy	±(accuracy of the power or current + 0.1 % of reading)
Timer*1	Selectable range	0 hours 00 minutes to 9999 hours 59 minutes
	Accuracy	±0.02 %

\*1 You can use the timer setting to automatically stop integration.

Other functions	
Synchronization source	Voltage/current/OFF (all display update intervals)
Display hold	Holds measured value. Possible to switch display items (measurement items).

Communication function
RS232C (standard), GPIB/USB (select either, factory option)

General specifications		
AC input	Nominal input rating	100 V to 240 V, 50 Hz to 60 Hz
	Voltage range	90 V to 250 V
	Maximum power consumption	70 VA
Withstand voltage	Between the voltage and current input terminals and the chassis and interface	1980 Vac for 5 minutes
	Between the voltage and current input terminals and the AC input	
	Between the voltage input terminals and the current input terminals	1500 Vac for 1 minute
Insulation resistance	Between the voltage and current input terminals and the chassis and interface	100 M Ω or greater at 500 Vdc
	Between the voltage and current input terminals and the AC input	
	Between the voltage input terminals and the current input terminals	
Environmental conditions	Operating environment	Indoor use, overvoltage category II
	Operating temperature	0 °C to +40 °C
	Operating humidity	20 %rh to 80 %rh (There shall be no condensation.)
	Storage temperature	-20 °C to +70 °C
	Storage humidity	90%rh or less (There shall be no condensation.)
Altitude	2000 m or less	
Earth continuity		0.1 Ω or less at 25 Aac
Safety*1		Complies with the requirements of the following directive and standard Low Voltage Directive 2006/95/EC*2 EN61010-1, class I, pollution degree 2
Electromagnetic compatibility (EMC)*1*2*3		Complies with the requirements of the following directive and standard EMC Directive 2004/108/EC EN 61326-1 Compliance condition: The maximum length of all cabling and wiring connected to the KPM1000 must be less than 3 m.
Dimensions		See the outline drawing
Weight		Approx. 2.5 kg (5.51 lb.)
Accessories	Power cord (three-pronged)	1
	Safety plugs (solder-connection type)	1 set (red and black)
	CD-ROM*4	1
	Quick start	English: 1, Japanese: 1
	Safety information	1 (contains English, Chinese, and Japanese)
	Packing list	1 (contains both English and Japanese)

\*1 Does not apply to specially ordered or modified KPM1000s.

\*2 Limited to products that have the CE mark on their panels.

\*3 The measured values may be affected by noise.

\*4 Use shielded cables for the communication cables. The act of connecting measuring cables may cause radio interference, in which case users may be required to correct the interference.

\*4 Contains the User's Manual, the Communication Interface Manual, and the KI-VISA library.

## Dimensions

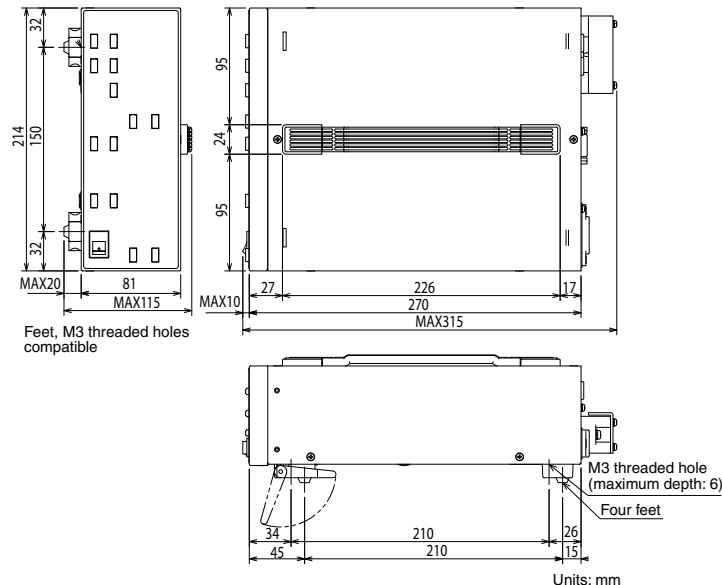

# Ordering Information

## Main unit

Model	Part	Remarks
KPM1000	Digital Power Meter	IEC62301 First Edition compliant



## Option



Test lead  
[TL40]  
Red/black One each  
1000V/ CAT II max 32A Length: 1m



Safety plug (threaded connection type)  
[TL41]  
Red/black One each  
1000V/ CAT II max 32A



Safety plug (clamped connection type)  
[TL43]  
Red/black One each  
600V/ CAT II max 10A



Alligator clip  
[TL44]  
Red/black One each  
1000V/ CAT II max 32A



Fork terminal adapter  
[TL45]  
Red/black One each  
1000V/ CAT II max 20A



Safety plug (soldered connection type)  
[TL42]  
Red/black One each  
1000V/ CAT II max 32A



AC outlet cable  
[OT01-KPM]  
125V/15A

AC Multi-outlet cable  
[OT02-KPM]  
250V/15A

### ● Other

Model	Part	Remarks
KRA2	Rack mount adapter (EIA)	Inch size, 2U width
KRA100	Rack mount adapter (JIS)	Millimeter size, 2U width
	GPIB interface ※	Factory option
	USB interface ※	
SD010-KPM	For IEC62301 measurement Application software	IEC62301 First Edition compliant

※ This is a factory option. Either one shall be attached to the main unit.



### KIKUSUI ELECTRONICS CORPORATION

1-1-3, Higashiyamata, Tsuzuki-ku, Yokohama, 224-0023, Japan  
Phone: (+81) 45-593-7570, Facsimile: (+81) 45-593-7571, www.kikusui.co.jp

KIKUSUI AMERICA, INC. 1-877-876-2807 [www.kikusuiamerica.com](http://www.kikusuiamerica.com)

2975 Bowers Avenue, Suite 307, Santa Clara, CA 95051  
Phone: 408-980-9433 Facsimile: 408-980-9409

KIKUSUI TRADING (SHANGHAI) Co., Ltd. [www.kikusui.cn](http://www.kikusui.cn)

Room 216, Building 4, No.641, Tianshan Road, Shanghai City, China  
Phone: 021-5887-9067 Facsimile: 021-5887-9069

For our local sales distributors and representatives, please refer to "sales network" of our website.

### ● Distributor/Representative

■ All products contained in this catalogue are equipment and devices that are premised on use under the supervision of qualified personnel, and are not designed or produced for home-use or use by general consumers. ■ Specifications, design and so forth are subject to change without prior notice to improve the quality. ■ Product names and prices are subject to change and production may be discontinued when necessary. ■ Product names, company names and brand names contained in this catalogue represent the respective registered trade name or trade mark. ■ Colors, textures and so forth of photographs shown in this catalogue may differ from actual products due to a limited fidelity in printing. ■ Although every effort has been made to provide the information as accurate as possible for this catalogue, certain details have unavoidably been omitted due to limitations in space. ■ If you find any misprints or errors in this catalogue, it would be appreciated if you would inform us. ■ Please contact our distributors to confirm specifications, price, accessories or anything that may be unclear when placing an order or concluding a purchasing agreement.