

Part No. Z1-004-002, IB013705

Nov. 2012

OPERATION MANUAL

AC Electronic Load

PCZ1000A

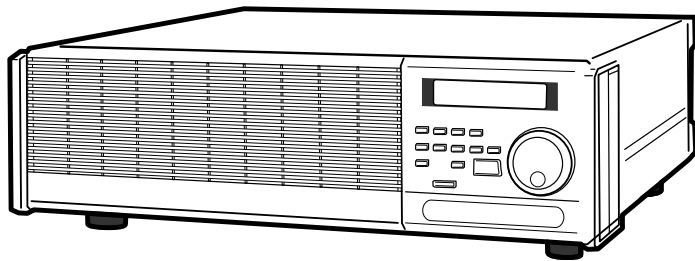

Use of Operation Manual

Please read through and understand this Operation Manual before operating the product. After reading, always keep the manual nearby so that you may refer to it as needed. When moving the product to another location, be sure to bring the manual as well.

If you find any incorrectly arranged or missing pages in this manual, they will be replaced. If the manual gets lost or soiled, a new copy can be provided for a fee. In either case, please contact Kikusui distributor/agent, and provide the “Kikusui Part No.” given on the cover page.

This manual has been prepared with the utmost care; however, if you have any questions, or note any errors or omissions, please contact Kikusui distributor/agent.

Reproduction and reprinting of this operation manual, whole or partially, without our permission is prohibited.

Both unit specifications and manual contents are subject to change without notice.

Copyright© 2007-2012 Kikusui Electronics Corporation

Power Requirements of this Product

Power requirements of this product have been changed and the relevant sections of the Operation Manual should be revised accordingly.

(Revision should be applied to items indicated by a check mark)

Input voltage

The input voltage of this product is _____ VAC,
and the voltage range is _____ to _____ VAC. Use the product within
this range only.

Input fuse

The rating of this product's input fuse is _____ A, _____ VAC, and _____ .



WARNING









- **To avoid electrical shock, always disconnect the power cord or turn off the switch on the switchboard before attempting to check or replace the fuse.**
 - **Use a fuse element having a shape, rating, and characteristics suitable for this product. The use of a fuse with a different rating or one that short circuits the fuse holder may result in fire, electric shock, or irreparable damage.**
-

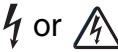



Safety Symbols

For the safe use and maintenance of this product, the following symbols are used throughout this manual and on the product itself. Note the meaning of each of the symbols to ensure safe use of the product. (Not all symbols may be used.)





	Indicates that a high voltage (over 1 000 V) is used here. Touching the part will result in a possibly fatal electric shock. If physical contact is required by your work, start work only after you make sure that no voltage is output here.
DANGER	Indicates an imminently hazardous situation which, if ignored, will result in death or serious injury.
 WARNING	Indicates a potentially hazardous situation which, if ignored, could result in death or serious injury.
 CAUTION	Indicates a potentially hazardous situation which, if ignored, may result in damage to the product and other property.
	Shows that the act indicated is prohibited.
	Indicates a general danger, warning, or caution. When this symbol is marked on the product, see the relevant sections in this manual.
	Protective conductor terminal.
	Chassis (frame) terminal.
	On (supply)
○	Off (supply)
	In position of a bi-stable push control
	Out position of a bi-stable push control





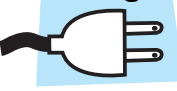

Safety Precautions

The following safety precautions must be observed to avoid fire hazards, electric shock, accidents, and other failures. Please keep these in mind and follow the instructions carefully.

Using the product in a manner that is not specified in this manual may impair the protection functions provided by the product.

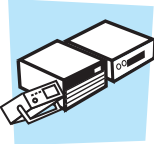
Users 	<ul style="list-style-type: none">• This product must be used only by qualified personnel who understand the contents of this operation manual.• If an unqualified person is to use the product, be sure the product is handled under the supervision of qualified personnel (those who have electrical knowledge). This is to prevent the possibility of personal injury.
Purpose of use 	<ul style="list-style-type: none">• Never use the product for purposes other than the product's intended use.• This product is not designed or manufactured for general home or consumer use.
Input power Line Voltage 	<ul style="list-style-type: none">• Use the product within the rated input power voltage range.• Use the power cord provided. For details, see the relevant page in the operation manual.• This product is a IEC Overvoltage Category II device (energy-consuming equipment supplied from the fixed installation).
Fuse 	<ul style="list-style-type: none">• The fuse can be replaced on this product. When replacing the fuse, use a fuse with the correct shape, rating, and characteristics for the product. For details, see the relevant page in the operation manual.
Cover 	<ul style="list-style-type: none">• Some parts inside the product may cause physical hazards. Do not remove the external cover.



<p>Grounding</p> 	<ul style="list-style-type: none"> • This product is an IEC Safety Class I device (device with protected conductor terminals). To prevent electric shock, be sure to connect the protective conductor terminal of the product to electrical ground (safety ground).
<p>Installation</p> 	<ul style="list-style-type: none"> • This product is designed for safe indoor use. Only use the product indoors. • Please read the section 2.2, "Precautions for Installation" section of this manual before installing the product and comply with the instructions.
<p>Relocation</p> 	<ul style="list-style-type: none"> • Turn off the POWER switch, and disconnect the cables before relocating the product. • The product weighs over 20 kg. When moving the product, have more than one person carry it. The weight of the product is indicated on the rear panel of the product and in the specification table in this manual. • When relocating the product, remember to also relocate the manual.
<p>Operation</p> 	<ul style="list-style-type: none"> • Before using the product, be sure to check the input power voltage and that there is no abnormality in the appearance of the AC power cord. Be sure to remove the power cord plug from the outlet before checking. • If a malfunction or abnormality is detected on the product, stop using it immediately, and remove the power cord plug from the outlet. Make sure the product is not used until it is completely repaired. • Use cables or wires with sufficiently large current capacity for output wires and load cables. • Do not disassemble or modify the product. If you need to modify the product, contact your Kikusui distributor or agent.
<p>Maintenance and inspection</p> 	<ul style="list-style-type: none"> • To prevent electric shock, be sure to turn off the switchboard breaker before carrying out maintenance or inspection. • Do not remove the external cover during maintenance or inspection. • To maintain the performance and safe operation of the product, it is recommended that periodic maintenance, inspection, cleaning, and calibration be performed.
<p>Service</p> 	<ul style="list-style-type: none"> • Kikusui service engineers will perform internal service on the product. If the product needs adjustment or repairs, contact your Kikusui distributor or agent.

How to Read This Manual

Introduction

Thank you for purchasing the PCZ1000A AC electronic load.

This manual is intended for first-time users of the PCZ1000A. It gives an overview of the PCZ1000A and describes various settings, program messages, maintenance, and precautions, etc.

Read this manual thoroughly to use the functions of the PCZ1000A effectively. You can also review this manual when you are confused about an operation or when a problem occurs.

How to read this manual

This manual is designed to be read from beginning to end. We recommend that you read this manual thoroughly from the beginning before using the PCZ1000A for the first time.

Intended readers of this manual

This manual is intended for users of the PCZ1000A or persons teaching other users on how to operate the PCZ1000A.

The manual assumes that the reader has knowledge about electronic load equipments.

Information on the remote control commands are provided with the premise that the reader has sufficient knowledge about controlling measuring instruments using a personal computer.

Structure of this manual

This operation manual consists of the following chapters. The following outlines each chapter.

Chapter 1 General Description

This chapter gives an overview and describes the features of the PCZ1000A.

Chapter 2 Unpacking and Installation

This chapter describes the necessary procedures from unpacking the product to preparation before use.

Chapter 3 Operation

This chapter describes each mode and function of the operation.

Chapter 4 Remote Control

This chapter describes how to program the remote control features of the PCZ1000A using an external device such as a personal computer. The explanation covers the command syntax, details of each command, and the registers.

Chapter 5 Maintenance and Calibration

This chapter describes the maintenance procedures including cleaning, inspection, and calibration.

Chapter 6 Specifications

This chapter gives the specifications and dimensions of the PCZ1000A.

Appendix

The appendix contains the basic operating modes, operating range, and troubleshooting.

Notation used in this manual

- The PCZ1000A AC electronic load is simply referred to as the PCZ1000A in this manual.
- The term "computer" is used to refer to a personal computer, workstation, or similar.
- The following markings are used in this manual.



Indicates a potentially hazardous situation which, if ignored, could result in death or serious injury.



Indicates a potentially hazardous situation which, if ignored, may result in damage to the product and other property.



Indicates information that you should know.



Explanation of terminology or operation principle.



Indicates a reference to detailed information.

SHIFT+key name (marked in blue)

Indicates an operation involving pressing the named key (printed in blue) when the LED above the SHIFT key illuminates after the SHIFT key is held down.

Contents

Power Requirements of this Product	i
Safety Symbols	iii
Safety Precautions	iv
How to Read This Manual	vi
Contents	viii
Function Index	xi
Front panel	xii
Rear panel	xiv

Chapter 1 General Description

1.1 About This Manual	1-2
1.2 Product Overview	1-2
1.3 Features	1-2
1.4 Options	1-3

Chapter 2 Unpacking and Installation

2.1 Unpacking Checks	2-2
2.2 Precautions for Installation	2-2
2.3 Precautions for Moving	2-4
2.4 Attaching to the Rack Mount Frame	2-5
2.5 Checking the Input Power and Fuse	2-6
2.6 Connecting the AC Power Cord	2-8
Procedure for Connecting the Power Cord	2-8
2.7 Load Wiring	2-9
2.7.1 Precautions Concerning Wiring	2-9
Overvoltage	2-10
Other Precautions	2-10
Input Voltage Waveforms	2-11
2.7.2 Connection to the Load Input Terminals	2-13

Chapter 3 Operation

3.1 Basic Panel Operation	3-2
Function Keys	3-2
Preset Memory Key	3-3
Other Keys	3-4
3.2 Turning On the Power	3-5
3.3 Load-On/Load-Off	3-6
3.4 Protection Functions and Alarms	3-7
Alarm Occurrence and Release	3-7
Protection Functions	3-7
3.5 Operation Modes	3-10
Operation Mode Display	3-10



3.5.1	CC Mode Operation	3-11
3.5.2	Constant Resistance (CR) Mode	3-12
3.5.3	Constant Power (CP) Mode	3-15
3.5.4	Crest Factor Function	3-16
3.6	Saving and Recalling Preset Memory	3-17
	Saving Preset Memory	3-18
	Changing Preset Memory	3-19
	Recalling Preset Memory	3-20
3.7	Parallel Operation and Tracking Operation	3-21
3.7.1	Configuration (CONFIG) Settings	3-21
	How to Display and Set Configuration Settings	3-22
3.7.2	Parallel Operation	3-23
	Procedure for Connecting Units in Parallel	3-24
	Procedure for Setting Master and Slave Units	3-25
3.7.3	Tracking Operation	3-27
	Connecting Units for Tracking Operation	3-28
	Procedure for Setting Master and Slave Units	3-28
3.7.4	Calibration of the Ammeter on the Master Unit During Parallel Operation	3-30
	Preparation for Calibration	3-30
	Calibration Procedure	3-31
3.7.5	Alarms During Parallel and Tracking Operation	3-33
3.7.6	Returning to Standalone Operation	3-33
3.8	Factory Default Settings	3-34

Chapter 4 Remote Control

4.1	Overview of Remote Control	4-2
4.1.1	RS232C Interface	4-2
4.2	Programming Format	4-4
4.2.1	Program Messages	4-4
4.3	Device Messages	4-5
4.3.1	Program Header and Program (Response) Data	4-5
4.3.2	Configuration of Device Messages	4-6
	Basic Messages	4-6
	System Messages	4-8
	Communication Settings and Control Codes	4-8
4.4	Assignment of Register Bits	4-9
	Fault Register	4-9
	Fault Register 2	4-9
	Error Register	4-10
	Communication Command Errors	4-10

Chapter 5 Maintenance and Calibration

5.1	Cleaning and Inspection	5-2
	Inspecting the Power Cord	5-2
	Cleaning the Panel	5-2

	Replacing the Backup Battery	5-2
	Cleaning the Dust Filter	5-2
5.2	Calibration	5-3

Chapter 6 Specifications

6.1	Specifications	6-2
6.2	Dimensions	6-5

Appendix

A.1	Explanation of Operating Functions	A-2
A.1.1	Operating Functions	A-2
	Operating Range	A-2
	Differences Between DC and AC Loads	A-2
A.1.2	Explanation of Operating Mode	A-4
	Constant-Current (CC) Mode	A-4
	Constant-Resistance (CR) Mode	A-5
	Constant-Power (CP) Mode	A-6
A.2	Troubleshooting	A-7

Index



Function Index

Preparation

Topic	Section in the Manual	 See Page
How do I check that all accessories are included.	Unpacking Checks	2-2
What precautions should I observe when installing?	Precautions for Installation	2-2
What precautions should I observe regarding grounding?	Connecting the AC Power Cord	2-8
What precautions should I observe regarding the load unit?	Load Wiring	2-9
How do I connect the power cord?	Connecting the AC Power Cord	2-8
How do I connect the load?	Connection to the Load Input Terminals	2-13
Where do I find detailed explanation of initial settings?	Turning On the Power	3-5
How do the protection functions work?	Protection Functions and Alarms	3-7
What settings are available?	Basic Panel Operation	3-2
What are the connector requirements and what is the procedure for connecting PCZ1000A units to operate in parallel?	Procedure for Connecting Units in Parallel	3-24

Operation

Topic	Section in the Manual	 See Page
How do I turn the power on and off?	Turning On the Power	3-5
How do I set the protection functions?	Protection Functions and Alarms	3-7
How do I use the PCZ1000A in constant-current mode?	CC Mode Operation	3-11
How do I use the PCZ1000A in constant-resistance mode?	Constant Resistance (CR) Mode	3-12
How do I use the PCZ1000A in constant-power mode?	Constant Power (CP) Mode	3-15
How do I use the Crest Factor function?	Crest Factor Function	3-16
How do I set the configuration (CONFIG)?	Configuration (CONFIG) Settings	3-21

Others

Topic	Section in the Manual	 See Page
How can I check whether the PCZ1000A is faulty?	Troubleshooting	A-7
How do I perform troubleshooting?		
Where do I find detailed command reference?	Programming Format	4-4
What do the remote control error messages mean?	Assignment of Register Bits	4-9
How do I perform maintenance?	Cleaning and Inspection	5-2
What is the procedure for calibration?	Calibration of the Ammeter on the Master Unit During Parallel Operation	3-30
How do I reset the PCZ1000A to the factory default settings?	Factory Default Settings	3-34

Front panel

Control panel

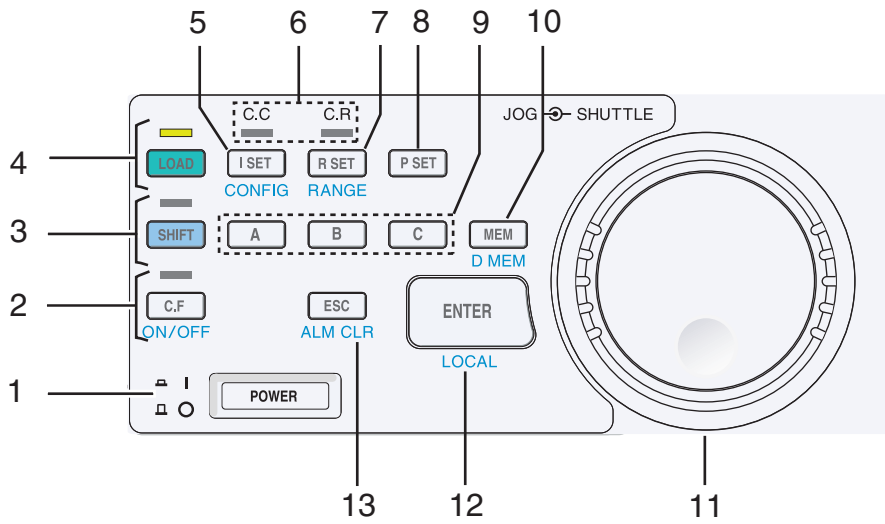

Display

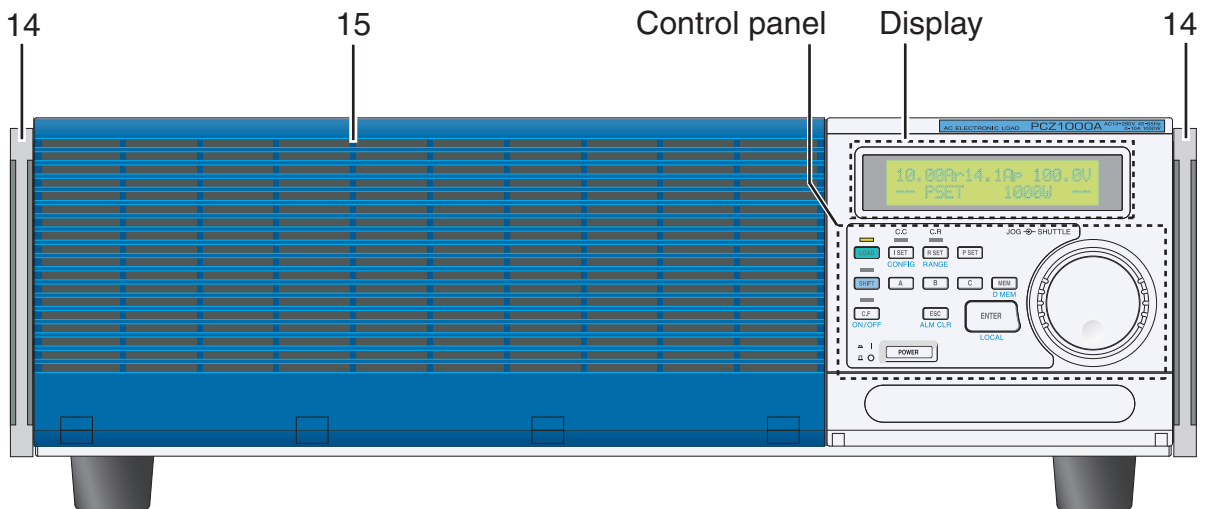
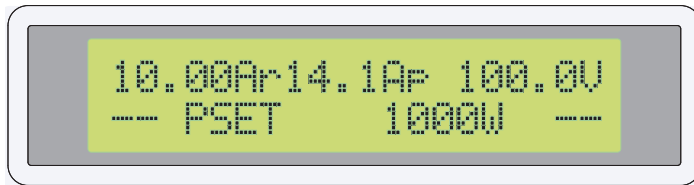

No.	Name		Explanation	See Page
		+SHIFT		
1	POWER		Power on/off switch The power is ON when the switch is in position () and OFF when the switch is out position (O).	3-5
2	C.F ON/OFF		Turns CF mode on or off.	3-3
	C.F LED		Illuminates to indicate when CF mode is on.	3-10
3	SHIFT		Enables keys indicated in blue.	-
	SHIFT LED		Illuminates to indicate when the SHIFT key is active.	
4	LOAD ON/OFF		Turns the load on or off.	3-2
	LOAD LED		Illuminates to indicate when the load is on.	-
5	I SET		Sets CC mode and to set the current limit using the jog and shuttle dial.	3-2
		CONFIG	Specifies various settings that control the operation.	3-21
6	C.C LED		Illuminates to indicate when CC or CP mode is on.	3-10
	C.R LED		Illuminates to indicate when CR or CP mode is on.	3-10
7	R SET		Sets CR mode and to set the resistance limit using the jog and shuttle.	3-3
		RANGE	Range selection key	
8	P SET		Sets CP mode and to set the power limit using the jog and shuttle.	3-3
9	A		Recalls the preset memory A value; pressing the MEM key and A saves the value to preset memory A.	3-3
	B		Recalls the preset memory B value; pressing the MEM key and B saves the value to preset memory B.	
	C		Recalls the preset memory C value; pressing the MEM key and C saves the value to preset memory C.	
10	MEM		Saves preset memory values.	3-3
		D MEM	Modifies preset memory values.	
11	Jog and shuttle dial		Fine and coarse adjustment of setting values	3-2
12	ENTER		Enter key for preset memory	3-4
		LOCAL	Local operation selection key	
13	ESC		Cancels the selected function.	3-4
		ALM CLR	Clears an alarm.	
14	Handle		Carrying handle.	2-5
15	Ventilation louvers		Provides ventilation for the unit. Fitted with an internal dust filter.	5-2

1

2

3

4

5

6

Appx.

Rear panel

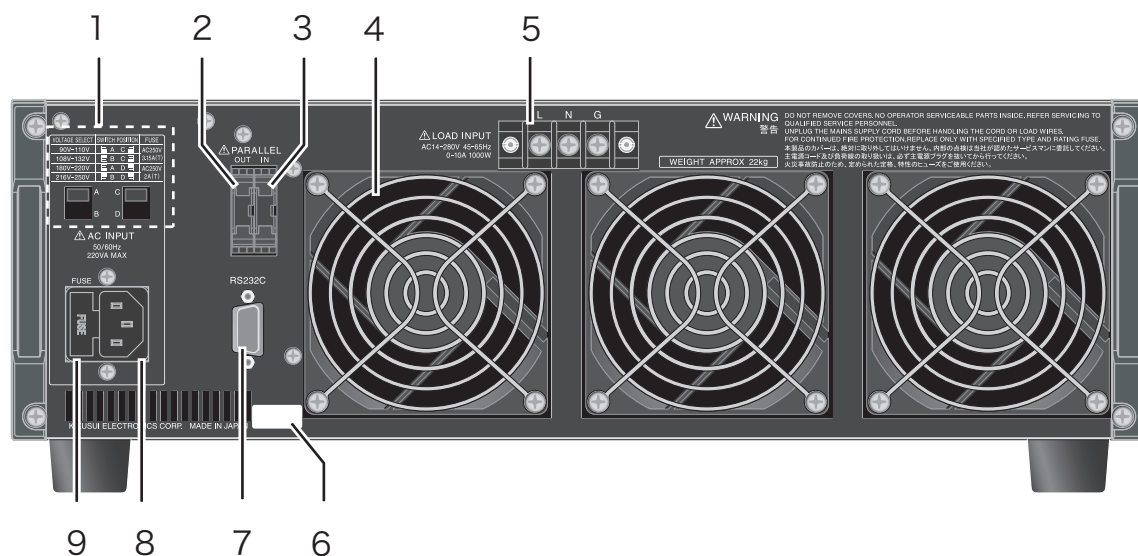

No.	Name	Explanation	See Page
1	Power supply voltage range selection switch	Switch for selecting the power supply voltage to be used	2-6
2	PARALLEL OUT	Connector for parallel operation (output). Incorporates a protective socket.	3-23
3	PARALLEL IN	Connector for parallel operation (input). Incorporates a protective socket.	
4	Ventilation outlets	Cooling ventilation outlets	2-2
5	LOAD INPUT	Load input terminals	2-9
6	Serial number	The serial number of the instrument	-
7	RS232C	RS232C connector used by the remote control function	4-2
8	AC INPUT	AC power supply inlet	2-8
9	FUSE	Power supply fuse holder, includes a spare fuse (1)	2-2, 2-6

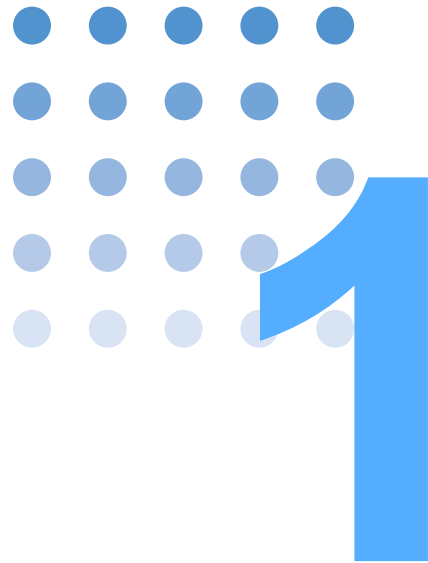

General Description

This chapter gives an overview and describes the features of the PCZ1000A.

1.1 About This Manual

This operation manual describes the PCZ1000A AC electronic load.

Applicable firmware versions

 page 3-5

This manual applies to PCZ1000A with firmware version 1.4x.

When making an inquiry about the product, please provide us with the following information:

- Model Name (PCZ1000A)
- Firmware version
- Serial number (indicated at the lower section on the rear panel)

1.2 Product Overview

The PCZ1000A is an AC electronic load featuring high reliability and safety. In addition to the resistive loads generally used in tests, it is capable of simulating capacitive-input rectifier loads.

1.3 Features

● Crest-factor function

In addition to the constant-current*, constant-resistance*, and constant-power* modes, the PCZ1000A also features a crest-factor function which is useful for load testing of peak or harmonic currents. This helps reduce design and labor time and cost as well as improve the quality of the equipment under test.

* The instrument always allows a current waveform close to a sine waveform to flow unaffected by the voltage waveform.

● Simple operation

The key features can be operated quickly on a one-key-to-one-feature basis. Fine adjustment is possible with the jog/shuttle rotary knob.

● Easy-to-see LCD with backlight

The instrument features an LCD with LED backlight, enabling a variety of operations to be performed. Test results are displayed clearly and are unaffected by ambient light.

● Parallel operation

Up to five units can be used in parallel under the control of a single master unit. A PCZ1000A can be set as a master and up to four slave PCZ1000As connected in parallel (max. 5 kW, 50 Arms). The total power is displayed on the front panel of the master unit.

- Tracking operation

Up to five units can be tracked

Setup values specified on the master unit are also applied to the slave units and any changes to the master unit settings are also applied immediately to the slaves. Useful for testing single-phase/three-wire or three-phase/three-wire AC power supply loads.

1.4 Options

The following options are available for the PCZ1000A.

For details on the options, contact your Kikusui agent or distributor.

■ Rack mounting option

Part Name	Model No.	Remarks
Rack mounting bracket	KRB3	For EIA standard inch units racks
	KRB150	For JIS standard metric units racks

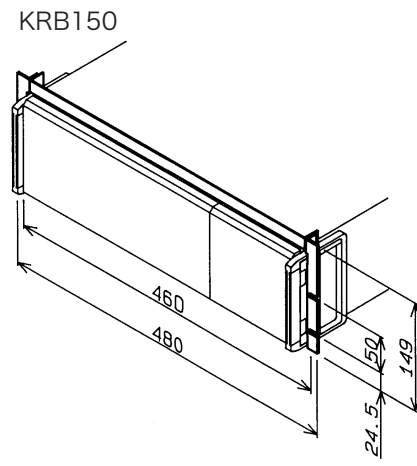
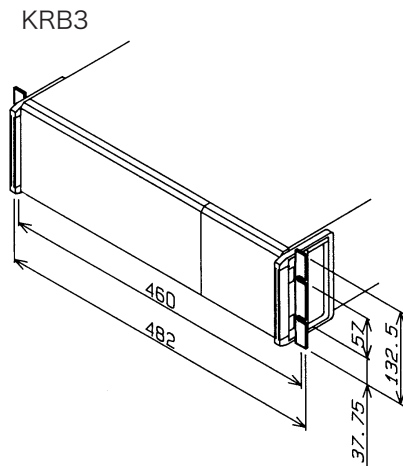

■ Signal cable for parallel operation

Cable used for parallel operation

Part name	Model No.	Remarks
Signal cable for parallel operation	PC01-PCZ1000A	300 mm, 10-pin

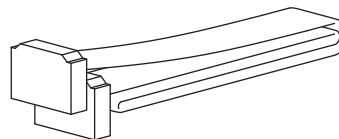





Unpacking and Installation

This chapter describes the necessary procedures from unpacking the product to preparation before use.

2.1 Unpacking Checks

Upon receiving the PCZ1000A, make sure the package contains all the necessary parts and that the PCZ1000A has not been damaged during transportation. If you find any damage or other problems, please contact your Kikusui distributor or agent.

We recommend that all packing materials are saved, in case the product needs to be transported at a later date.

Accessories

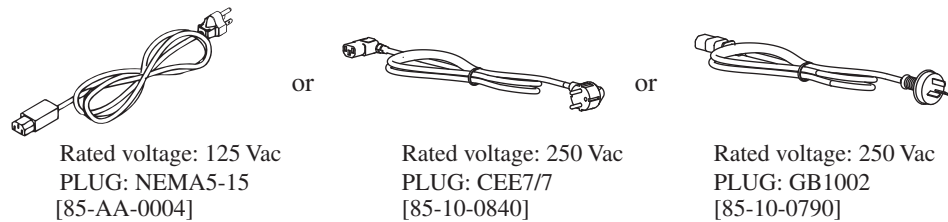

Power cord (1 pc.)

The supplied power cord and spare fuses are different depending on the line input voltage range set when the instrument was shipped.

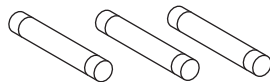

Spare fuses (3 pcs.)

Line input voltage range set when the instrument was shipped	For 100 V system	In AC inlet	100 V, 3.15A (1 pc.) [99-02-0037]
		Also supplied	200 V, 2A (2 pcs.) [99-00-0026]
	For 200 V system	In AC inlet	200 V, 2A (1 pc.) [99-00-0026]
		Also supplied	100 V, 3.15A (2 pcs.) [99-02-0037]

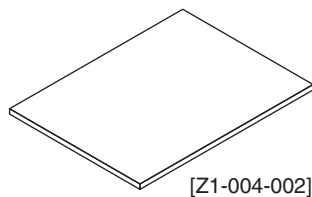

Manual (1 copy)

Fig.2-1 Accessories

2.2 Precautions for Installation

Be sure to observe the following precautions when installing the product.

- Do not use the PCZ1000A in a flammable atmosphere.

To prevent explosion or fire, do not use the product near alcohol, thinner, or other combustible materials, or in an atmosphere containing such vapors.

- Avoid locations where the PCZ1000A is exposed to high temperatures or direct sunlight.

Do not locate the product near a heater or in areas subject to drastic temperature changes.

Operating temperature range: 0 °C to 40 °C (32 °F to 104 °F)

Storage temperature range: -25 °C to 70 °C (-13 °F to 158 °F)

- Avoid humid environments.

Do not locate the PCZ1000A in a high-humidity environment near a boiler, humidifier, or water supply.

Operating humidity range: 20 %rh to 85 %rh (no condensation)

Storage humidity range: 90 %rh or less (no condensation)

Condensation may occur even within the operating humidity range. In that case, do not start using the product until the location is completely dry.

- Be sure to use the PCZ1000A indoors.

This PCZ1000A is designed for safe indoor use.

- Do not place the PCZ1000A in a corrosive atmosphere.

Do not install the product in a corrosive atmosphere or one containing sulfuric acid mist or the like. This may cause corrosion of various conductors and imperfect contact with connectors, leading to malfunction and failure or, in the worst case, a fire.

- Do not locate the PCZ1000A in a dusty environment.

Dirt and dust in the product may cause electrical shock or fire.

- Do not use the PCZ1000A where ventilation is poor.

Secure adequate space around the product so that air can circulate around it. Allow at least 20 cm of space between the air inlet/outlet and the wall (or obstacles).

- Do not place any object on the PCZ1000A.

In particular, do not place heavy objects on the product as this could result in a malfunction.

- Do not place the PCZ1000A on a tilted surface or in a location subject to vibrations.

If placed on a non-level surface or in a location subject to vibration, the product may fall, resulting in damage and injury.

- Do not stand the PCZ1000A in upright position.

It may cause injury to the operator or the damage to the product when it falls down.

- Do not use the PCZ1000A in a location where strong magnetic or electric fields are present or with an input power supply with significant waveform distortion or noise.

The PCZ1000A may malfunction.

- Use the PCZ1000A in an industrial environment.

The PCZ1000A may cause interference if used in residential areas. Such use must be avoided unless the user takes special measures to reduce electromagnetic emissions to prevent interference to the reception of radio and television broadcasts.

2.3 Precautions for Moving

When moving or transporting the PCZ1000A to an installation site, observe the following precautions.

- Turn off the POWER switch.

Moving the PCZ1000A with the power on may result in electrical shock or damage.

- Remove all wiring.

Moving the PCZ1000A with cables connected may cause wires to break or injuries due to the product falling over.

- The PCZ1000A should always be moved by more than one person.

The PCZ1000A should be relocated by no less than two persons. Take extra care when placing the unit on a tilted or uneven surface. Never lay the unit on its side or turn it upside down.

- When transporting the PCZ1000A, be sure to use the original packing material.

Transport the PCZ1000A in its original package to prevent vibration and falls, which may damage the PCZ1000A.

- Be sure to include this manual.

To use the handles, pull them from the instrument body as shown in Fig.2-2.

Simultaneously slide the two locks in each handle in the UNLOCK direction, and then pull the handle towards you until it clicks into place. The handle can now be used to carry the device.

To store the handles, simultaneously slide the two locks in the UNLOCK direction, and then push the handles forward. This locks the handles into place.

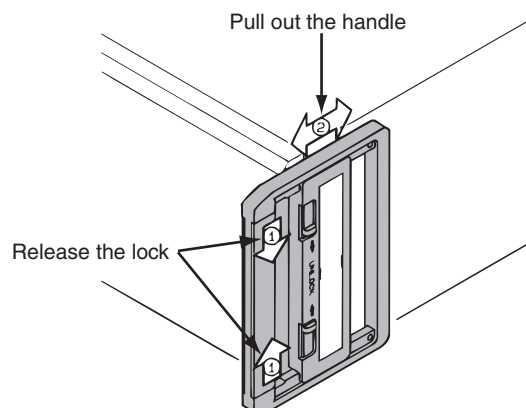

Fig.2-2 Pulling Out the Handles

2.4 Attaching to the Rack Mount Frame

Before installing the rack mount frame, remove the four M4 screws and rubber feet. Fig.2-3 shows how to remove the rubber feet.

Refer to the KRB3 and KRB150 user guides for details about how to attach to the rack.

We recommend that you keep all the parts so that you can use them again when you detach the product from the frame.

To reattach the rubber feet, use the screws that you removed.

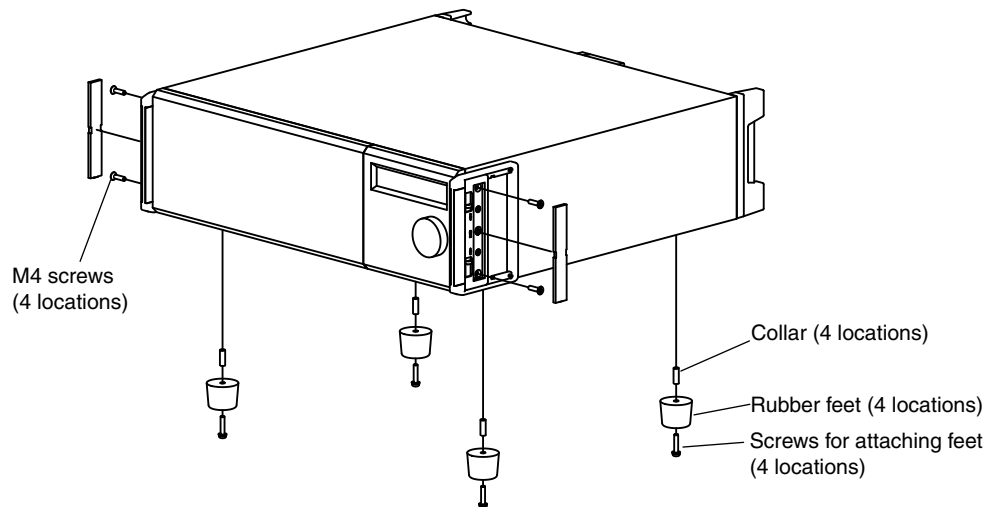

Fig.2-3 How to Remove the Rubber Feet

How to remove the rubber feet

Undo the screws and remove the four rubber feet.

2.5 Checking the Input Power and Fuse

The PCZ1000A is used by selecting one of the four input line voltage ranges shown in Fig.2-4. Check that the factory default setting is correct for the AC line input voltage you will be using. Also, ensure that the line fuse is properly rated for the AC line supply.

⚠ WARNING • To avoid electric shock, always unplug the AC power cord before checking or replacing the fuse.

⚠ CAUTION • Select replacement fuses of the same type, rating, and characteristics as those provided with the PCZ1000A. Using a fuse with an incorrect rating or using the PCZ1000A with the fuse holder short-circuited may damage the PCZ1000A.

Follow the procedure below to check or change the voltage input range and to check or replace the line input fuse:

- 1 Turn OFF the POWER switch.
- 2 Disconnect the AC power cord from the PCZ1000A.
- 3 Confirm that the position of voltage range selection switch on the rear panel of the PCZ1000A matches the line input voltage to be used.
To change the settings, set the SWITCH POSITION as shown in Fig.2-4.
Use a flathead screwdriver to change the voltage settings.

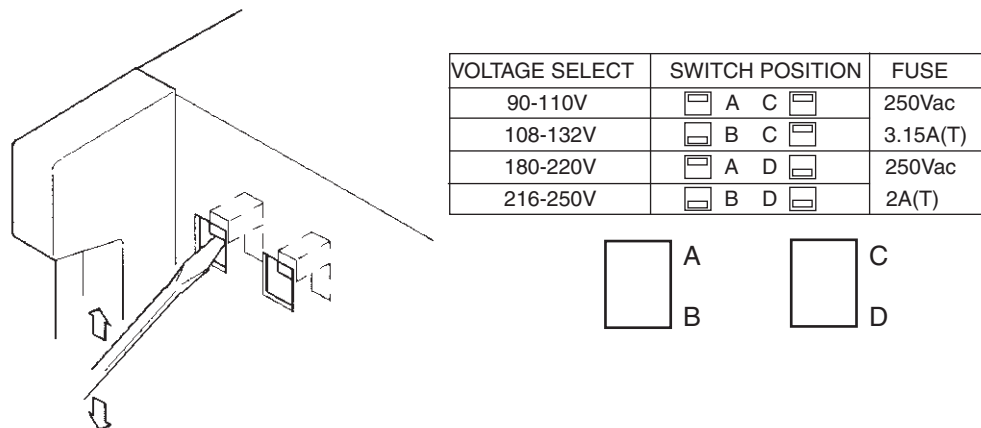

Fig.2-4 Input Voltage Range Selection Switch

- 4 Insert the screwdriver as shown in Fig.2-5.
- 5 Move the screwdriver in the direction indicated by the arrow to lever the fuse holder out of the PCZ1000A.
- 6 Confirm that the rating of the installed fuse is appropriate for the line voltage to be used. Also check that the time-current characteristics are appropriate for the application.
Always replace with the correct fuse.

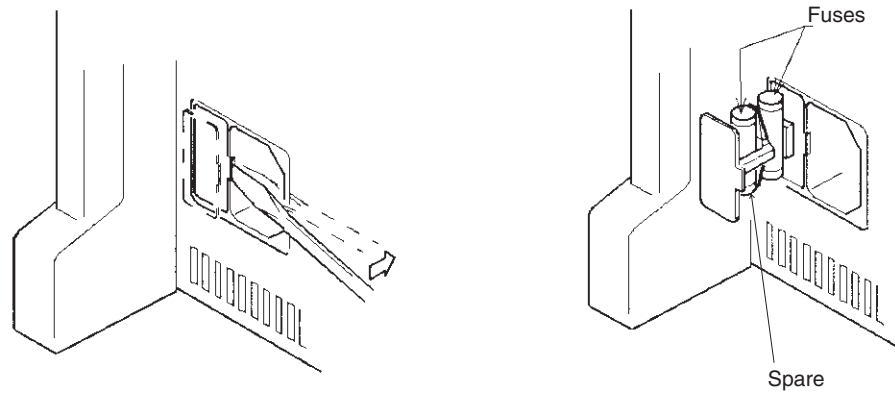

Fig.2-5 Removing the Fuse Holder

2.6 Connecting the AC Power Cord

- WARNING**
- The PCZ1000A is an IEC Safety Class I equipment (equipment with protected conductor terminals). To prevent electric shock, be sure to ground (earth) the unit.
 - This unit is grounded through the ground wire of the power cord. Be sure to connect the power plug to an outlet with an appropriate earth ground.

- NOTE**
- Use the supplied AC cable to connect to the AC power line. If the supplied cable cannot be used because the rated voltage is different or the plug does not fit the socket, have a qualified electrician replace it with a suitable cable no more than 3 m in length. Please contact your local Kikusui agent or distributor if you have any difficulty in obtaining a suitable power supply cable.
 - The power cord and plug can be used to disconnect the unit from the AC power line in case of emergency. Always plug the cable into a convenient nearby socket from which you can unplug it quickly if necessary and provide sufficient space around the socket.
 - Please do not use the supplied power cord on any other equipment.

The PCZ1000A is an IEC Overvoltage Category II device (energy-consuming equipment supplied from the fixed installation).

Procedure for Connecting the Power Cord

- 1 Turn off the POWER switch.
- 2 Check that the AC power line is compatible with the input power ratings of the PCZ1000A.
The PCZ1000A can be used with power supplies with voltages between 100 Vrms and 240 Vrms, and with a frequency of 50 Hz or 60 Hz.
- 3 Connect the AC cable to the AC inlet (AC LINE) on the rear panel and plug the other end to an outlet with proper grounding.

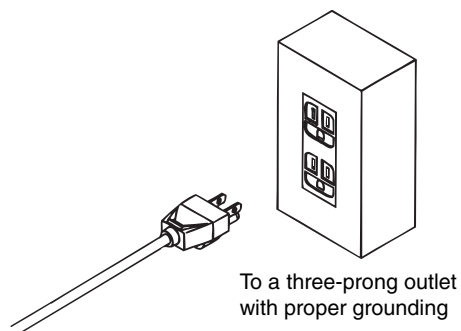

Fig.2-6 Grounding

2.7 Load Wiring

To ensure that the functions of the PCZ1000A work accurately and reliably, all wires must be connected correctly to their loads.

2.7.1 Precautions Concerning Wiring

Electric wire used



WARNING

- **Risk of fire.** Ensure that the cables used to connect the PCZ1000A to the equipment under test have sufficient current-carrying capacity compared to the rated input current of the PCZ1000A.
- **Risk of electric shock.** To ensure sufficient insulation compared to the isolation voltage ± 500 Vdc, use a reinforced insulation cable (UL1032 cable or equivalent) for the cables used to connect the PCZ1000A to the equipment under test.

See Table 2-1 for details of the cables to use to connect to the load input terminals, and ensure that the cross-section area of the cables is adequate to carry the allowable current recommended by Kikusui over and above the actual current level to be used. Also, please use cables with insulation able to withstand temperatures of 75 °C or higher.

Table 2-1 Nominal Cross-Section Area and Allowable Current for Cabling

Nominal Cross-Section Area [mm ²]	AWG	(Reference cross-section area) [mm ²]	Allowable Current *1 [A] (Ta = 30 °C)	Current Recommended by Kikusui [A]
2	14	(2.08)	27	10
3.5	12	(3.31)	37	-
5.5	10	(5.26)	49	20
8	8	(8.37)	61	30
14	6	(13.3)	88	50
22	4	(21.15)	115	80
30	2	(33.62)	139	-
38	1	(42.41)	162	100
50	1/0	(53.49)	190	-
60	2/0	(67.43)	217	-
80	3/0	(85.01)	257	200
100	4/0	(107.2)	298	-
125	-	-	344	-
150	-	-	395	300
200	-	-	469	400

*1. Excerpts from Japanese laws related to electrical equipment.

■ Load wire inductance

If the load wire is long or has a large loop, the wire inductance is increased.

In such condition, the input voltage may fall below the minimum operating voltage of the PCZ1000A causing the current waveform to be distorted. In some cases, the input voltage may exceed the maximum input voltage and cause damage to the PCZ1000A. The phase lag of the current may cause instability in the PCZ1000A control inducing oscillation.

Connect the PCZ1000A and the equipment under test using the shortest twisted wire possible to keep the voltage caused by inductance within the minimum operating voltage and maximum input voltage range.

A capacitor may be connected to the load input terminal as shown in Fig.2-7 to alleviate oscillation. In this case, use the capacitor within its allowable ripple current.

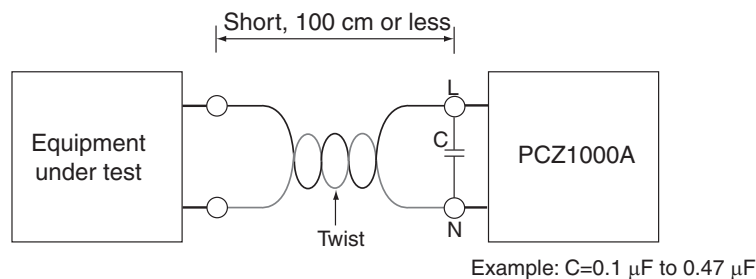

Fig.2-7 Wiring Length

Overvoltage

-
- ⚠ CAUTION** • Risk of damage to the instrument. The maximum input voltage is 400 V_{peak}. Do not apply voltages exceeding the maximum voltage of 400 V_{peak} to the load input terminals.
-

The maximum voltage that can be applied to the load input terminals is 400 V_{peak}. The PCZ1000A cannot be used with voltages higher than this.

If an excessive voltage is applied, an alarm will be displayed, a warning sounded, and the load disconnected. Please reduce the voltage of the equipment under test.

Other Precautions

-
- ⚠ CAUTION** • The L and N load terminals are connected internally through 0.01 μF capacitors to the G terminal (case) on the PCZ1000A to filter noise from the equipment under test. Thus, if one end of the output terminals of the equipment under test (EUT) is grounded, a small leak current (approx. 1 mA max.) will flow from the output terminals to the PCZ1000A case (ground). However, when operating a number of PCZ1000As in parallel, the maximum leak current will be multiplied by the number of PCZ1000As.
-

Input Voltage Waveforms

The PCZ1000A controls the amplitude of the sinusoidal current by detecting the RMS value of the input voltage waveform.

In the following cases, distortion may appear on the current waveform and the load current operation may become unstable.

If the input voltage changes suddenly, the current value will momentarily become unstable (response time: approximately 1 s).

If the frequency of the input voltage changes suddenly, the power waveform will be distorted for a few cycles. (See Fig. 2-8. The smaller the change in frequency, the less distortion is generated.)

Input of DC voltage or voltage out of the rated frequency range results in abnormal operation. (If the input voltage is exceeding the rated frequency range, the PCZ1000A will maintain the waveform until complete synchronization <1> in Fig.2-8. If the input voltage is less than the rated frequency range, it will maintain the waveform until complete synchronization <2> in Fig.2-8. In the case of a DC voltage, no current flows.)

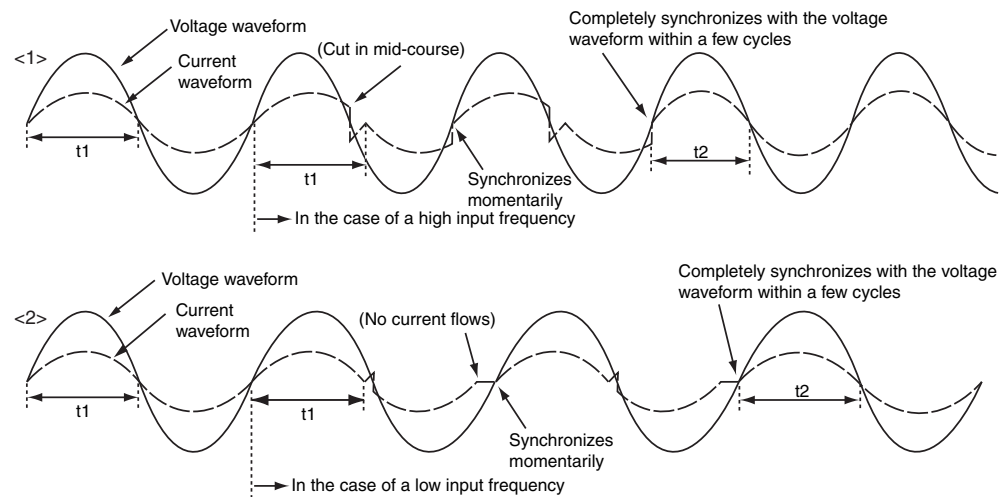

Fig.2-8 Current Distortion for a Sinusoidal Input Voltage

Even if the voltage waveform is a square wave as in <1> in Fig.2-9, a sinusoidal current will flow independently of the input voltage waveform. However, distortion may appear on the current waveform and the load current operation may become unstable in the period when the input voltage in <2> in Fig.2-9 is at 0 V. Please do not input voltages that include 0 V to the PCZ1000A.

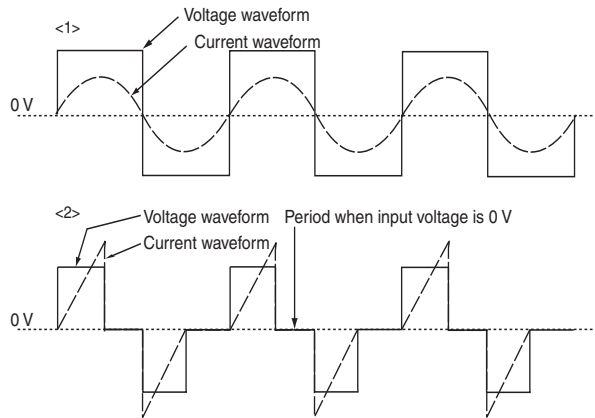

Fig.2-9 Current Distortion When the Input Voltage is a Square Wave

Distortion may also appear on the current waveform and the load current operation may become unstable if a voltage with a DC offset is input as in Fig.2-10. Please do not input voltage waveforms with a DC offset to the PCZ1000A.

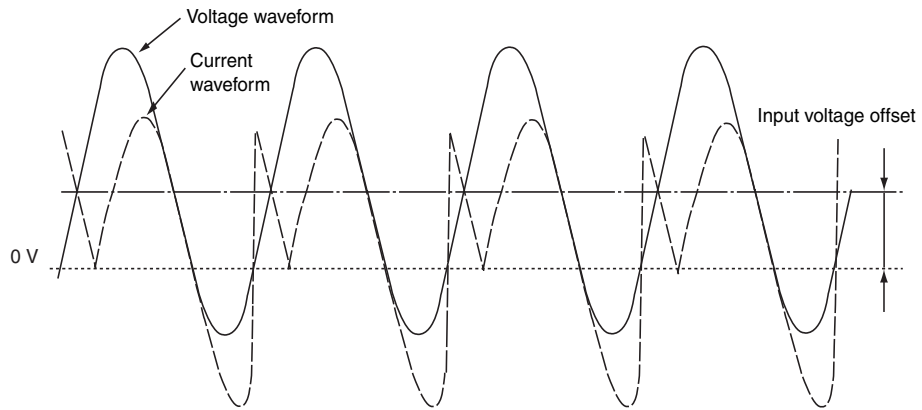

Fig.2-10 Input Voltage Offset

2.7.2 Connection to the Load Input Terminals

■ Load input terminals cover

This cover is fitted using the hole on the right side of the terminal cover when the PCZ1000A is shipped from the factory to prevent the load input terminals from being exposed.

Please attach the cover as shown in Fig.2-11 when not using the load input terminal block. The load input terminals can be covered by using the hole on the right and sliding the terminal cover to the left.

Use the hole on the right to attach the terminal cover.

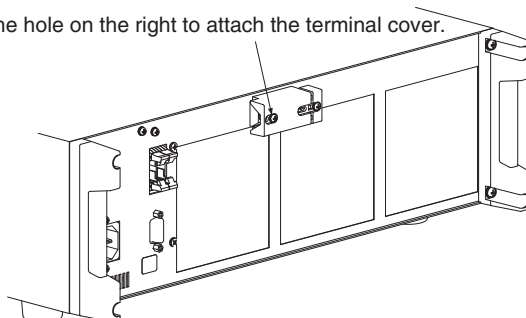

Fig.2-11 Load Input Terminals Cover

⚠ WARNING

- **Risk of electric shock. Never touch the load input terminals when they are live.**
Also, always use the load input terminals cover.

⚠ CAUTION

- Risk of damage.
- Never connect the load input terminals to the equipment under test while the PCZ1000A is in the load-on state.
 - Never connect the load input terminals to the AC power line directly.

- 1 Turn off the POWER switch.
- 2 Remove the terminal cover from the load input terminal block.
- 3 Attach crimped terminals to the load wiring.
Use proper crimped terminals that suit the terminal screw size (M4).
- 4 Securely connect the load wiring to the load input terminals.
If the equipment under test has a ground terminal (GND), always connect this to the G terminal on the load input terminal block of the PCZ1000A.
- 5 Attach the terminal cover removed in Step 2 using the hole provided on the right of the terminal cover as shown in Fig.2-12.

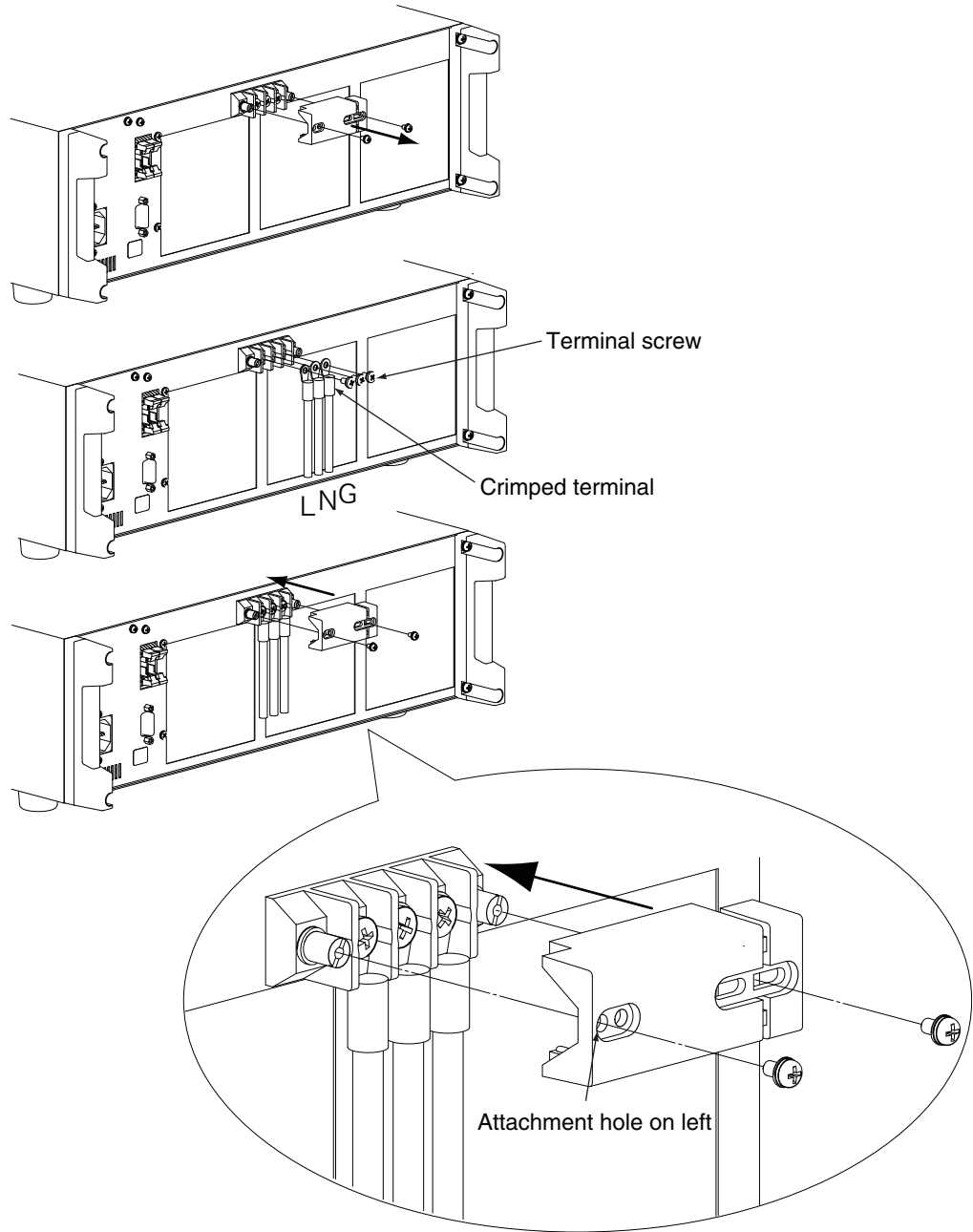
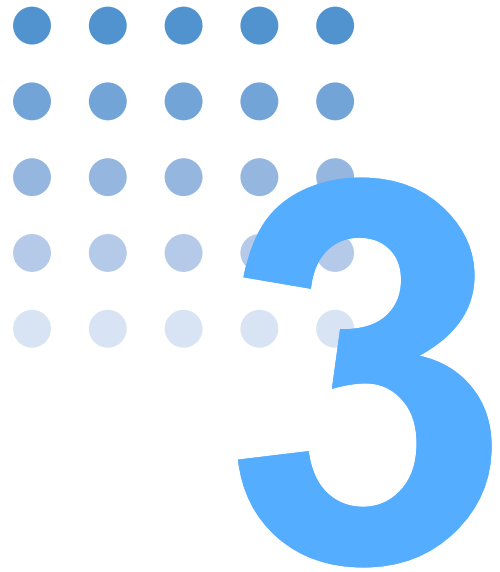

Fig.2-12 Connecting the Load Input Wiring



Operation

This chapter describes each mode and function of the operation.

3.1 Basic Panel Operation

The main operations of the PCZ1000A can be selected simply by pressing the function keys shown in Fig.3-1. Pressing the ESC key clears the currently selected function.

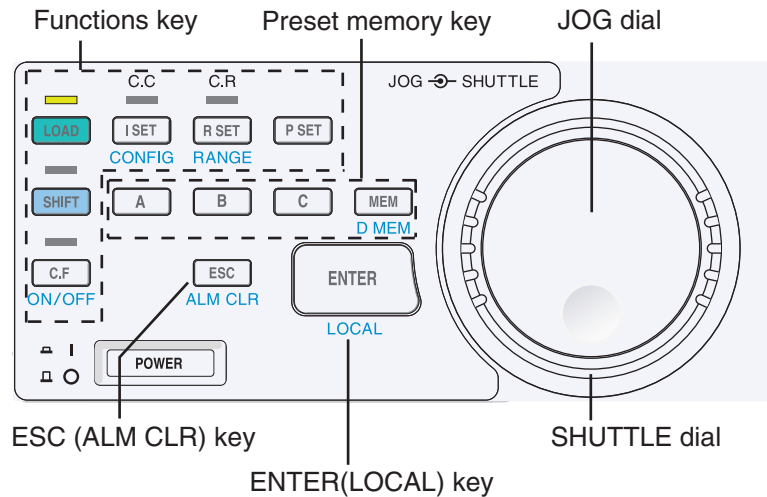

Fig.3-1 Operation Controls on Front Panel

How to use the JOG/SHUTTLE dial

The inner JOG dial is used to select display items and for fine adjustment of setting values. The outer SHUTTLE dial changes the setting value at a rate that is proportional to how far the dial is turned. That is, the further the dial is turned the faster the rate of change, and vice versa. Use the SHUTTLE dial for large changes in setting value.

Function Keys

LOAD

Starts or stops load current flow. When the key is pressed, the LED above it illuminates. Pressing the LOAD key again the LED goes off and turns off the load.

I SET (CONFIG)

The I SET key enables CC mode. The CC lamp above the key illuminates, and "ISET" appears on the display. This key enables the constant-current setting value (ISET) to be changed with the JOG/SHUTTLE dial.

While the SHIFT key is pressed and the LED above the SHIFT key illuminates, pressing the I SET allows the various CONFIG settings to be specified.

R SET (RANGE)

The R SET key enables CR mode. The CR lamp above the key illuminates and "RSET" appears on the display. This key enables the constant-resistance setting (RSET) to be changed with the JOG/SHUTTLE dial.

To select the range function, press the SHIFT key and then, after the SHIFT LED above the SHIFT key illuminates, press the R SET (RANGE) key. The range switches between "H" and "L" each time the R SET (RANGE) key is pressed.

P SET

The P SET key enables CP mode. Both the CC and CR LEDs illuminate and "PSET" appears on the display. This key enables the constant-power setting (PSET) to be changed with the JOG/SHUTTLE dial.

C.F key

The C.F. key enables the CF function. Press the SHIFT key and then, after the SHIFT LED above the key illuminates, press the C.F. key. The LED above this key illuminates, and "CREST FACTOR" appears on the display. This key enables the crest factor to be changed with the JOG/SHUTTLE dial.

Preset Memory Key

MEM (DMEM)

To save the active setting and range in the selected memory location, select memory save mode and then press the A, B, or C key. To select the memory modify function (DMEM), press the SHIFT key and then, after the LED above the key illuminates, press the MEM (DMEM) key. The memory modify function changes the setting stored in memory A, B, or C only and does not change the present active setting.

To reset each setting to its default value, turn on the POWER switch with the MEM key held down.

A, B or C

Calls up and displays a setting stored in memory A, B or C. In the memory save mode, these keys select memory A, B or C.

 page 3-34

Other Keys

ESC (ALM CLR)

Clears the currently selected function.

To clear an alarm and halt the alarm sound, holding down the SHIFT key and then, after the LED above the SHIFT key illuminates, press the ESC key to invoke the ALM CLR function. Note that a new alarm will be displayed and the alarm warning sounded if any of the conditions that caused the alarm are still present.

ENTER (LOCAL)

Confirm the setting value called up from preset memory. To select the local function (LOCAL), press the SHIFT key and then, after the LED above the key illuminates, press the ENTER (LOCAL) key. This switches operation from remote control (via an external computer) to the local (front-panel) operation.

During remote control operation, "REM" is displayed at the bottom right of the front panel display as shown in Fig.3-2.

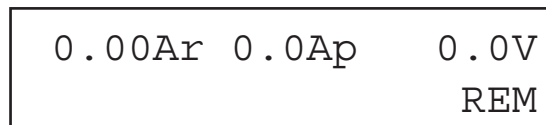

A rectangular display box containing the following text: "0.00Ar 0.0Ap 0.0V" on the top line and "REM" on the bottom line, positioned towards the right side.

Fig.3-2 Remote Control Display

Invalid operations

A warning "pip" tone sounds if you try to select any invalid settings or press any inappropriate keys during operation.

3.2 Turning On the Power

See page 3-6

This section describes the procedure for turning on the power. No load current will flow if the PCZ1000A is turned on with its factory default settings. To allow a load current to flow, the PCZ1000A needs to be set to load-on mode.

- CAUTION**
- Allow at least five seconds between turning the POWER switch on or off. In-rush current of up to 80 A can occur at power on. Turning the POWER switch on and off repeatedly during a short interval can result in the blown input fuse.

Turning on the POWER switch

See page 2-8 , 2-13

- 1 Check that the POWER switch is OFF (O).
- 2 Check that all wiring connections are properly connected.
- 3 Turn the POWER switch to ON (I).
- 4 Check the firmware version on the front panel display.
The front panel display shows the model name and firmware version.

```
PCZ1000A
Ver. 1.00
```

The front panel display changes after approximately 2 seconds.

```
0.00Ar 0.0Ap 0.0V
-- ISET 0.00A --
```

The upper part indicates the RMS current (Ar), peak current (Ap), and RMS voltage (V) supplied to the load terminals of the PCZ1000A. The lower part shows the operation mode (the above example shows "I SET" which indicates constant current mode) and the setting (0.00 A in the above example).

See page 3-34

When the POWER switch is turned on for the first time after purchase, the PCZ1000A will start up in its factory default state.

■ When an error occurs

In case the calibration data is changed to the abnormal value caused by deterioration of the internal memory and the like, "xx xxx EPPDATA ERR" ("x" may varies depends on the contents of the error) is displayed with the buzzer sounds when the POWER switch is turned on . It will return to the normal display in three seconds, however, the error for the setting value and the ammeter/voltmeter may become large because of the calibration data is not properly confirmed.

- CAUTION**
- If the PCZ1000A is used while the error is occurred, it causes the failure. Contact your Kikusui distributor/agent for repairs.

Turning off the POWER switch

Turn the POWER switch to OFF (O).

The backup function of the PCZ1000A saves the following settings when the POWER switch is turned off.

When the power is turned off, the PCZ1000A automatically memorizes and saves the settings (setup) that are in use. The settings and initial values saved by this function are listed below. Those in parentheses are initial values.

- ISET value
- PSET value
- Range in the CR mode
- Contents of memories A, B, and C
- RSET value
- CREST FACTOR value
- C.F on/off
- CONFIG setting

The load on/off state is not stored. The PCZ1000A always starts up with the load turned off when the power is turned on.

If the PCZ1000A is not turned on with the condition of the last setting when the POWER switch was turned off, the life of back-up battery may be dead.

See page 5-2

3.3 Load-On/Load-Off

The PCZ1000A switches between the load-on and load-off states each time the LOAD key is pressed. If the protection function operates, the PCZ1000A goes to load-off automatically.

- Load-on: Load current is on
The LED above the LOAD key illuminates.
- Load-off: Load current is disconnected
The LED above the LOAD key turns off.

CAUTION

- Risk of damage to the PCZ1000A. Only connect the output of the equipment under test to the PCZ1000A input when it is set to the load-off state. Do not change to load-on until after connecting. If you do connect to the PCZ1000A input when it is in the load-on state, ensure that the output for the equipment under test is turned off.
If a relay, electromagnetic circuit breaker, or similar is connected between the output terminals of the equipment under test and the load input terminals, only turn the relay or circuit breaker on when in the load-off state and do not change to load-on until after turning on the input.
-

3.4 Protection Functions and Alarms

If an abnormal input is detected by the internal circuit of the PCZ1000A, the PCZ1000A automatically goes to load-off to protect the equipment under test, an alarm message appears on the lower part of the front panel display, and a buzzer sounds. The PCZ1000A is equipped with the following protection functions and alarms.

- Overcurrent Protection (OCP)
- Overpower Protection (OPP)
- Peak Overcurrent Protection (POCP)
- Internal circuit protection (FUSE BRK)
- External alarm 1(EXT1)
- Overvoltage Protection (OVP)
- Overheat Protection (OHP)
- External alarm 2 (EXT2)

Alarm Occurrence and Release

Alarm occurrence

An alarm is triggered when a protection function activates. When an alarm occurs, the PCZ1000A goes to the load-off state, displays an alarm message on the lower part of the front panel display, and sounds a buzzer.

Clearing an alarm

A generated alarm can be cleared by pressing the SHIFT + ESC key. If you cannot clear the alarm even when all of the causes of the alarm are eliminated, the PCZ1000A may have malfunctioned. If this happens, stop using the PCZ1000A and contact your Kikusui agent or distributor.

Protection Functions

The alarm displayed on the front panel display is the most recent alarm message to have been detected.

Overcurrent protection (OCP)

The OCP function is activated if the current reaches 11.5 Arms or more. In this case, the buzzer sounds and the PCZ1000A automatically goes to the load-off state.

The following message appears in the lower part of the front panel display.

ALARM OCP

See page 2-10

Overvoltage protection (OVP)

The OVP function is activated if a voltage of 470 V_{peak} or greater is applied to the load terminals. In this case, the buzzer sounds and the PCZ1000A automatically goes to the load-off state. Please check the output voltage of the equipment under test immediately.

The following message appears in the lower part of the front panel display.

ALARM OVP

Overpower protection (OPP)

The OPP function is activated if the input power exceeds 1 150 W. In this case, the buzzer sounds and the PCZ1000A automatically goes to the load-off state.

The following message appears in the lower part of the front panel display.

ALARM OPP

See page 2-4

Overheat protection (OHP)

The OHP function is activated if the temperature of the internal power supply unit rises abnormally. In this case, the buzzer sounds and the PCZ1000A automatically goes to the load-off state. Check that the operating temperature is within the range 0 to 40 degrees C and check whether the fan motor has shutdown, or whether the front or rear ventilation slots are blocked. Also check whether the dust filter for the front ventilation slots is clogged. If clogged, see "Cleaning the Dust Filter" on page 5-2.

The following message appears in the lower part of the front panel display.

ALARM OHP

Internal circuit protection (FUSE BRK)

If the internal fuse blows, the FUSE BRK is activated, the buzzer sounds, and the PCZ1000A automatically goes to the load-off state.

The following message appears in the lower part of the front panel display.

ALARM FUSE BREAK

Peak overcurrent protection (POCP)

The POCP function is activated if the current reaches 48 A_{peak} or greater. In this case, the buzzer sounds and the PCZ1000A automatically goes to the load-off state.

The following message appears in the lower part of the front panel display.

ALARM POCP

External alarm 1 (EXT1)

If a protection function is activated on a PCZ1000A when used in parallel or tracking operation, the protection alarm appears on the front panel display of the PCZ1000A on which the alarm occurred and the external alarm 1 message appears on the other PCZ1000As. The master unit and slave units all go to the load-off state.

The buzzers on the PCZ1000A other than the one where the alarm was triggered sound with a longer time interval.

The following message appears in the lower part of the front panel display on the PCZ1000A other than the one where the alarm was triggered.

ALARM EXT1

NOTE

- If the POWER switch is turned off on any PCZ1000A that is not in an alarm state, regardless of whether it is the master or slave, an external alarm 1 occurs on the other PCZ1000As.

External alarm 2 (EXT2)

This alarm is triggered after approximately 30 seconds if the flat cable used to connect PCZ1000As during parallel or tracking operation becomes disconnected. A buzzer sounds and the PCZ1000A automatically goes to the load-off state.

The buzzer is sounded with a longer time interval as for an external alarm 1.

The following message appears in the lower part of the front panel display.

ALARM EXT2

WARNING

- **Risk of electric shock. If the flat cable used to connect PCZ1000As in parallel becomes disconnected during parallel or tracking operation, turn the POWER switch on all the PCZ1000As to OFF before reconnecting.**

NOTE

- Note that, if the flat cable used to connect PCZ1000As in parallel becomes disconnected during parallel or tracking operation, the ammeter (rms and peak) on the master unit will not read correctly.
- External alarm 2 does not update the fault register.
- An external alarm 2 will occur after approximately 30 seconds if a unit is set to slave operation when operating in standalone mode.

3.5 Operation Modes

The PCZ1000A has the following four operation modes. The crest factor function is also available in constant-current mode.

- Constant-current mode (CC mode)
- Constant-resistance mode (CR mode)
- Constant-power mode (CP mode)
- Constant-current + Crest Factor function

Operation Mode Display

The currently selected operation mode is indicated by the LEDs on the operation panel.

CC mode:	The C.C LED above the I SET key illuminates.
CR mode:	The C.R LED above the R SET key illuminates.
CP mode:	Both the C.C and C.R LEDs illuminate.
CF function:	The C.F LED above the C.F key illuminates. Because the CREST FACTOR function is only used in CC mode, the C.C LED also illuminates.

If the operating point of the PCZ1000A is limited by an operation mode other than the selected mode, the relevant LED blinks.

C.C LED blinks:	The PCZ1000A is operating in the CP range even though CC mode is selected.
C.R LED blinks:	The PCZ1000A is operating in the CC or CP operation range even though CP mode is selected.
CC and CP LEDs both blink:	The PCZ1000A is operating in the CC operation range even though CP mode is selected.

NOTE

- In CP mode, the PCZ1000A may not reach the CP operation range and may operate in the CC operation range if the input voltage is low. This causes both the C.C and C.R LEDs to blink. For example, when 1000 W is set as the PSET value and 10 A is set as the ISET value, the instrument will not enter the CP operation range unless the input voltage is 100 Vrms or more. In the same way, when the PSET value is 140 W, the PCZ1000A will not enter the CP operation range unless the input voltage is 14 Vrms or more. In the range in which the input voltage is 10 V rms or less, the PCZ1000A is unable to sink its maximum current (10 Arms; see "Operation range of the PCZ1000A" above). Thus, even when a current of the ISET value or less flows, the PCZ1000A apparently operates in the CC operation range, causing both the C.C and C.R LEDs to blink. In particular, near an input voltage of 0 Vrms, the CC operation current becomes almost 0 Arms. This causes both the C.C and C.R LEDs to blink, even when no power supply under test is connected to the PCZ1000A.
-

3.5.1 CC Mode Operation

In constant current (CC) mode, set a current limit [A] value.

Current limit setting range: 0.00 Arms to 10 Arms

Fig.3-3 shows the front panel display when in constant current mode. The input terminal measurements are displayed on the upper side.

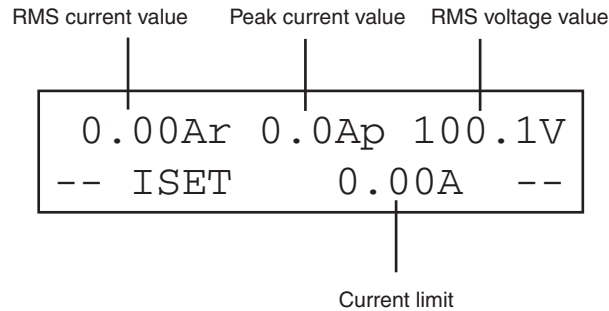
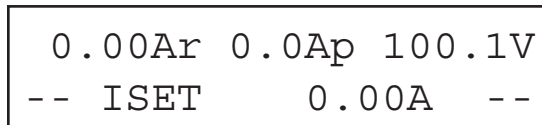
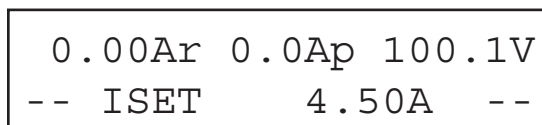

Fig.3-3 Display in CC Mode

- 1 If the LED above the LOAD key is on, press the LOAD key to turn it off.
- 2 Press the I SET key to enable CC mode.
The LED above the I SET key illuminates.



- 3 Turn the SHUTTLE dial clockwise to set the current limit value approximately.



- 4 Turn the JOG dial clockwise to set the exact current limit value.

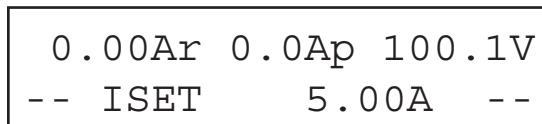

- 5 Press the LOAD key to change to the load-on state.
The LED above the LOAD key illuminates and current flow starts.

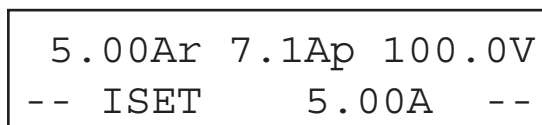

- 6 Press the LOAD key to go to the load-off state.
The LED above the LOAD key turns off.

```

0.00Ar 0.0Ap 100.1V
-- ISET 5.00A --

```

NOTE

- An offset current of several tens of mA may flow if the current limit value is set to approximately 0 A. (The setting accuracy of the PCZ1000A is $\pm (1 \% + 0.1 \text{ A})$.)
- The current limit value and the resolution at close to 0 A may be degraded due to this offset current. (The setting resolution is the minimum possible change in setting value.)

3.5.2 Constant Resistance (CR) Mode

Constant resistance (CR) mode works by setting a resistance limit value [Ω].

Resistance limit value setting range:

H level: 1 Ω to 1 k Ω

L level: 10 Ω to 10 k Ω

Fig.3-4 shows the front panel display when set to constant resistance mode. The input terminal measurements are displayed on the upper side.

RMS current value	Peak current value	RMS voltage value
<pre> 0.00Ar 0.0Ap 85.0V -- RSET 1000.0Ω H-- </pre>		
	Resistance limit	Range

Fig.3-4 Display in CR Mode

- 1 If the LED above the LOAD key is on, press the LOAD key to change to load-off.
- 2 Press the I SET key and set the current limit to 10.5 A.
The value displayed on the front panel display is the CC mode value.

See Fig.3-3

```

0.00Ar 0.0Ap 85.0V
-- ISET 10.50A --

```

- 3 Press the R SET key to enable CR mode.

The LED above the R SET key illuminates.

```
0.00Ar 0.0Ap 85.0V
-- RSET 1000.0Ω H--
```

- 4 Turn the SHUTTLE dial clockwise to set the resistance limit value approximately.

```
0.00Ar 0.0Ap 85.0V
-- RSET 11.905Ω H--
```

- 5 Turn the JOG dial clockwise to set the exact value.

```
0.00Ar 0.0Ap 85.0V
-- RSET 10.000Ω H--
```

- 6 Press the LOAD key to change to the load-on state.

The LED above the LOAD key illuminates and current flow starts.

```
8.49Ar 12.0Ap 84.9V
-- RSET 10.000Ω H--
```

- 7 Use the JOG/SHUTTLE dial to set the resistance limit value.

Changing the resistance limit value during load-on also changes the current. In this example, the current value displayed at the top left changes to 9.51 A as a result of changing the resistance limit value to 8.9285 Ω

```
9.51Ar 13.5Ap 84.9V
-- RSET 8.9285Ω H--
```

- 8 Use the SHIFT + R SET (RANGE) key to change the range.

As this example changes to the L range, the resistance is limited to the minimum value for the L range (9.0000 Ω in this example) and so the current reduces. It is not possible to set the resistance limit to less than the minimum value.

If the resistance limit value is within the region where the H and L ranges overlap (9.0000 Ω to 1000.0 Ω), the resistance limit value remains unchanged when the range is switched.

However, because the setting resolution is different in the two ranges, the setting changes to the next highest resistance value for the new range.

```
9.43Ar 13.3Ap 84.9V
-- RSET 9.0000Ω L--
```

-
- 9 To set the range back to H, press the SHIFT + R SET (RANGE) key to change the range indicator to H.

The resistance limit value changes from the previous L range limit value (9.0000 Ω) to the next highest H range resistance setting (9.0090 Ω).

9.42Ar	13.3Ap	84.9V
-- RSET	9.0090 Ω	H--

NOTE

- Setting range for H range: 1 Ω to 1 k Ω
Setting range for L range: 10 Ω to 10 k Ω
Although the setting range specifications are as listed above, the L range actually permits settings from 9.0000 Ω to 10.000 k Ω
Accordingly, in the example in step 8, the minimum value when changing to the L range is 9.0000 Ω and the range in which the H and L ranges overlap is 9.0000 Ω to 1000.0 Ω
 - The setting resolution and operating range for the L range is one tenth of the H range in units of siemens.
 - The units for the setting resolution of the resistance limit value is S (siemens).
Accordingly, you may sometimes not be able to set your desired resistance limit. In this case, the PCZ1000A is set the next highest resistance value allowed by the resolution.
For example, if operating in the H range by remote control, sending a setting input of 251 Ω (3.98 mS) will result in an actual setting of 333.33 Ω (3 mS).
 - If the resistance limit setting is such that the current is close to 0 A (for example, if the resistance limit is set to 10 k Ω for a 10 V input), an offset current of several tens of mA may flow. (The setting accuracy of the PCZ1000A is \pm (2 % + 0.2 A).)
 - The actual resolution at close to 0 A may be degraded due to this offset current. (The setting resolution is the minimum possible change in setting value.)
-

3.5.3 Constant Power (CP) Mode

Constant power (CP) mode works by setting a power limit value (W).

Setting range for power limit: 50 W to 1000 W

Fig.3-5 shows the front panel display when set to constant power mode. The input terminal measurements are displayed on the upper side.

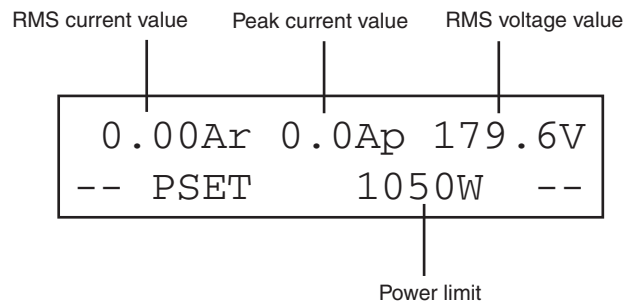
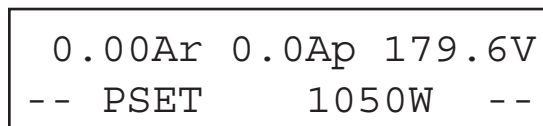
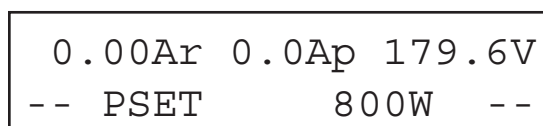

Fig.3-5 Display is CP Mode

- 1 If the LED above the LOAD key is on, press the LOAD key to change to load-off.
- 2 Press the P SET key to enable CP mode.
The C.C and C.R LEDs illuminate.



- 3 Use the JOG/SHUTTLE dial to set the power limit value.



- 4 Press the LOAD key to change to the load-on state.
The LED above the LOAD key illuminates and current flow starts.

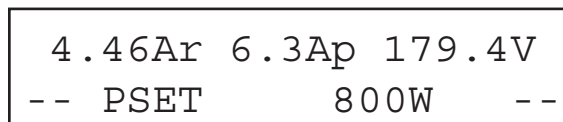

3.5.4 Crest Factor Function

The Crest Factor function simulates the current waveform of a capacitive input rectified load.

Fig.3-6 shows the front panel display of the crest factor setting. The input terminal measurements are displayed on the upper side.

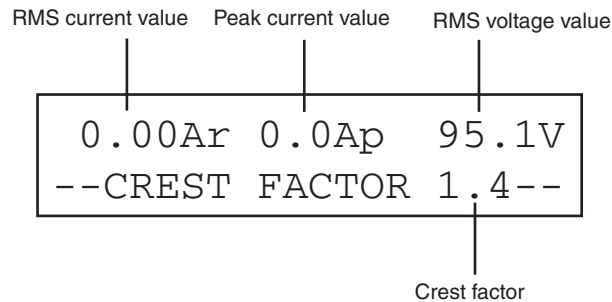

Fig.3-6 Crest Factor Setting Display

- 1 If the LED above the LOAD key is on, press the LOAD key to change to load-off.
- 2 Press the I SET key to enable CC mode.
The C.C LED at the top of the panel illuminates.
- 3 Press the SHIFT + C.F key to enable the crest factor function.
The LED above the C.F key illuminates.

The figure shows a rectangular display area with two lines of text. The top line contains three values: '0.00Ar', '0.0Ap', and '95.1V'. The bottom line contains '-- ISET 7.00A --'.

- 4 Pressing the C.F key again allows the crest factor setting to be specified (the existing setting appears in the lower part of the display).
"CREST FACTOR" appears in the lower part of the display.

The figure shows a rectangular display area with two lines of text. The top line contains three values: '0.00Ar', '0.0Ap', and '95.1V'. The bottom line contains '--CREST FACTOR 1.4--'.

- 5 Use the JOG/SHUTTLE dial to set the crest factor. (The crest factor is set to 2.0 in this example.)

The figure shows a rectangular display area with two lines of text. The top line contains three values: '0.00Ar', '0.0Ap', and '95.1V'. The bottom line contains '--CREST FACTOR 2.0--'.

6 Press the LOAD key to change to the load-on state.

The LED above the LOAD key illuminates. "CREST FACTOR" appears in the lower part of the display to indicate that the Crest Factor function is operating.

```
7.00Ar14.0Ap 95.0V
--CREST FACTOR 2.0--
```

At this time, the RMS current from the equipment under test can be changed by pressing the I SET key to change the current limit value while leaving the crest factor unchanged (remains set to 2.0 in this example). Similarly, the C.F key can be pressed again to change the crest factor setting.

```
8.00Ar11.3Ap 95.0V
-- ISET      8.00A --
```

7 Press the SHIFT + C.F key again to end the crest factor function.

NOTE

- Changing the crest factor setting does not change the current limit value. In other words, this can be used to change the peak current value only while leaving the RMS value of the current unchanged.
- The crest factor function can only be used in CC mode.

3.6 Saving and Recalling Preset Memory

Three preset memories (A, B, and C) are available in each mode and can be used to save and recall the following settings. DMEM key allows you to change only the limit values and the ranges stored in memory, retaining the current limit values. Crest factors cannot be modified using the DMEM key.

CC mode	Current limit, CF function (crest factor setting)
CR mode	Resistance limit, range setting
CP mode	Power limit

Saving Preset Memory

This saves the limit value and range settings displayed on the front panel. The example described below saves RSET:10 Ω and range: H in preset memory A.

- 1 Press the R SET key.
- 2 Use the JOG/SHUTTLE dial to set the resistance limit to 10 Ω .
- 3 Use the SHIFT + R SET (RANGE) key to set H range.

Example: RSET: 10 Ω , Range: H

```
8.49Ar12.0Ap 84.9V
-- RSET 10.000 $\Omega$  H--
```

- 4 Press the MEM key.
"MEM<ABC>Save Mode" appears on the lower part of the front panel display.

```
8.49Ar12.0Ap 84.9V
-- MEM<ABC>Save Mode
```

- 5 Press the A, B or C key to save to one of the preset memories.
Example: Save in preset memory A.

```
8.49Ar12.0Ap 84.9V
-- MEM<ABC>Save A --
```

- 6 Press the MEM or ESC key to end the save operation.
The display returns to its state prior to saving.

NOTE

- To save the crest factor value in CC mode to memory, first set the crest factor value and then press the I SET key to change to CC mode, then press the MEM key followed by the A, B, or C key to save the value of current limit and crest factor together.
-

Changing Preset Memory

The following example explains how to change the range for the limit value saved in preset memory A for CR mode and how to change the limit value saved in preset memory C.

- 1 Press the R SET key.

The resistance limit value and range are displayed in CR mode.

```
7.13Ar10.1Ap 84.9V
--RSET 11.111Ω H--
```

- 2 Press the SHIFT + MEM (DMEM) key.

The settings are stored in preset memory A. Pressing the A key displays "Rval" in the lower part of the display (the letter enclosed in "< >" indicates the preset memory location.)

```
7.13Ar10.1Ap 84.9V
--Rval<A>10.000Ω H--
```

- 3 Press the A key.

- 4 Press the SHIFT + RSET (RANGE) key.

This changes the range from "H" to "L". The range changes to the new setting immediately.

```
7.13Ar10.1Ap 84.9V
--Rval<A>10.000Ω L--
```

- 5 Press the SHIFT + MEM (DMEM) key or ESC key to end the operation.

- 6 Press the SHIFT + R SET (RANGE) key.

- 7 Press the C key.

- 8 Use the JOG/SHUTTLE dial to change the limit value.

The limit value changes to the new setting immediately.

```
7.13Ar10.1Ap 84.9V
--Rval<C>9.0909Ω H--
```

- 9 Press the SHIFT + MEM (DMEM) key or ESC key to end the operation.

The display returns to its state prior to the change.

Recalling Preset Memory

Memory settings for the currently set mode can be recalled regardless of whether the PCZ1000A is in the load-on or load-off state. The following example describes how to recall preset memory in CR mode.

- 1 Press the R SET key to enable CR mode.

```
7.13Ar10.1Ap 84.9V
-- RSET 11.904Ω H--
```

- 2 Press the key (A, B or C) corresponding to where the preset memory settings are stored.

The limit value saved in preset memory is displayed in the lower line enclosed in << <<.

```
7.13Ar10.1Ap 84.9V
<< RSET 10.000Ω H<<
```

- 3 Press the ENTER key. The present limit value changes to the applied setting limit value from the recalled preset memory.

To cancel without setting the recalled value, cancel the operation by pressing the ESC key instead of the ENTER key.

```
8.49Ar12.0Ap 84.9V
-- RSET 10.000Ω H--
```

3.7 Parallel Operation and Tracking Operation

Parallel operation

It is possible to increase the current and power capacity by connecting a number of PCZ1000As in parallel. Up to four PCZ1000As can be connected in parallel with one unit acting as the master unit and the others as slave units. The master unit acts as the master to control the other slave units.

Tracking operation

Tracking operation means that the setting values specified on the master unit are also applied to the slave units, and any changes to the master settings also apply simultaneously to the slaves. Up to four PCZ1000As can be connected in parallel with one unit acting as the master unit and the others as slave units.

This function is useful for testing single-phase/three-wire or three-phase/three-wire AC power supplies.

NOTE

Parallel operation and tracking operation cannot be used in the following combinations.

- Combination with PCZ1000As and PCZ1000s (older models).
- Combination with PCZ1000As with firmware version 1.40 or later and PCZ1000As with less than version 1.40.

3.7.1 Configuration (CONFIG) Settings

The operation of the PCZ1000A can be set to standalone operation, parallel operation, tracking operation, or total current calibration by the configuration setting.

Pressing the SHIFT + I SET (CONFIG) key brings up the configuration screen.

The following configuration settings are available.

Table3-1 CONFIG Settings List

No.	Setting	Setting Values	Related Sections
1	Norm /M/S	NORMAL, MASTER, SLAVE	Standalone operation, parallel operation, tracking operation
2	Para /Track	PARALLEL, TRACKING	Parallel operation, tracking operation
3	Parallel Ope.	2, 3, 4, 5	Parallel operation
4	Calibration	Push [I SET]	Parallel operation

How to Display and Set Configuration Settings

Fig.3-7 shows the configuration settings display.

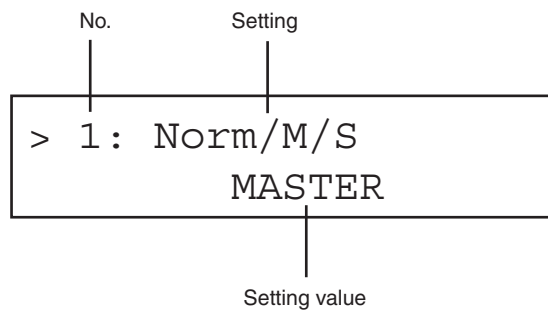

Fig.3-7 Example Configuration Settings Display

- 1** Press SHIFT + I SET (CONFIG).
The front panel shows the setting number, setting name, and current value, as shown in Fig.3-7.
- 2** Use the JOG/SHUTTLE dial to select the setting value.
- 3** Press the ENTER key to move to the next setting.
- 4** Repeat Step 2 and Step 3 to specify the other settings.
- 5** Use the SHIFT + I SET (CONFIG) key or ESC key to exit configuration setting.

3.7.2 Parallel Operation

The front panel display on the master unit shows the total current for the units connected in parallel.

The measurement accuracy can be improved by performing calibration in the parallel configuration.

The setting resolution for parallel operation is different depending on the number of instruments used.

Ammeter accuracy (RMS) : $\pm 2\%$ of FS

Ammeter accuracy (PEAK): $\pm 4\%$ of FS

Always keep the load wiring away as possible from the flat cable to prevent possible unstable operation.

See page 3-24

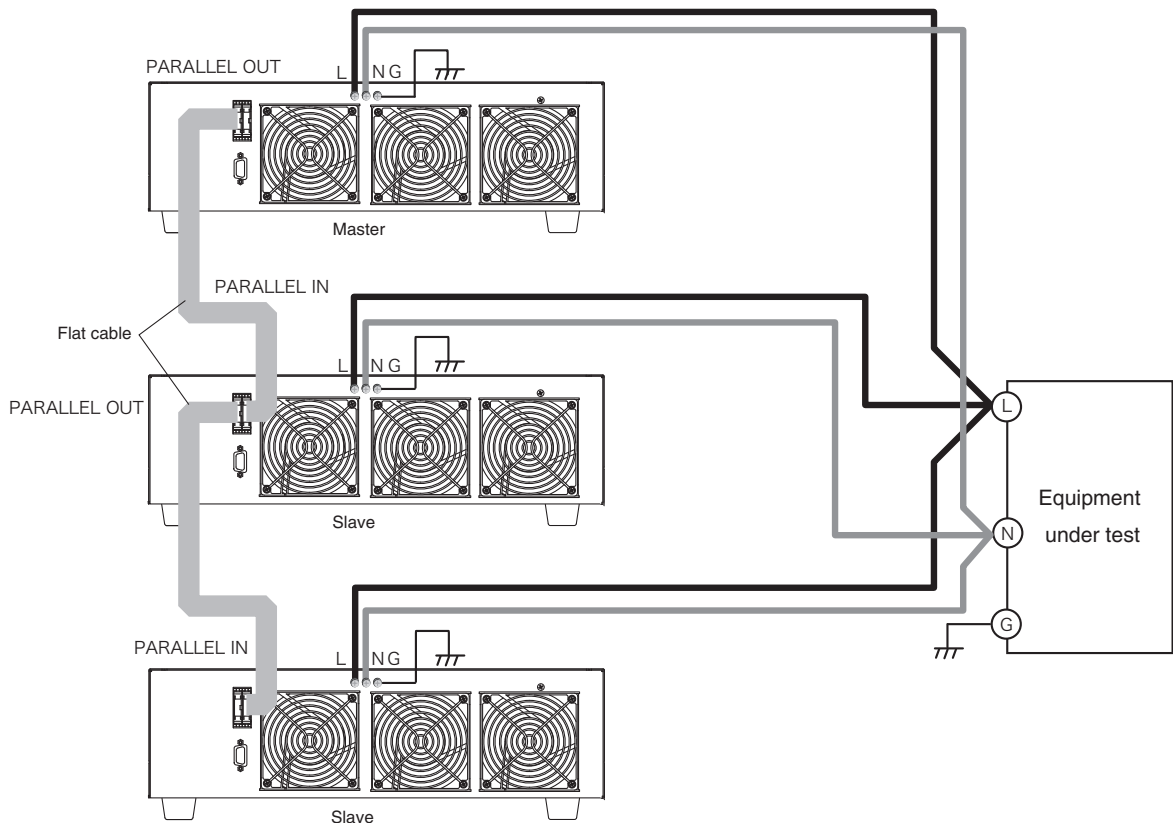

Fig.3-8 Parallel Connection with Two Slave Units

Table 3-2 shows the relation between the capacity and the number of parallel units.

Table 3-2 Capacity and Number of Parallel Units

No. of Slave Units	Maximum Current (RMS)	Maximum Current (Peak)	Maximum Power
1	20 A	80 A	2000 W
2	30 A	120 A	3000 W
3	40 A	160 A	4000 W
4	50 A	200 A	5000 W

Procedure for Connecting Units in Parallel

Parallel operation requires connection of a signal cable between the loads and a load cable that connects to the equipment under test.

For the signal cable, always use the flat cable (PC01-PCZ1000A) available as an option. Use load cables for the connection from the PCZ1000A to the equipment under test.

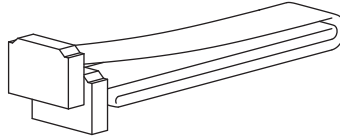

Fig.3-9 Flat Cable for Parallel Operation, Available as an Option

WARNING Risk of electric shock

- Turn off the **POWER** switch when you are touching the load input terminals, **PARALLEL IN** connector, or **PARALLEL OUT** connector. Also, re-attach the load input terminal cover after connecting the cables.
- Always fit the protective socket when not using the **PARALLEL IN** connector or **PARALLEL OUT** connector.
- If the flat cable used for parallel operation becomes disconnected during parallel or tracking operation, turn off the **POWER** switch on each unit before reconnecting.

CAUTION Risk of damage to the instrument

- Take care not to get the **PARALLEL IN** connector and **PARALLEL OUT** connector mixed up.
- Ensure that the load cable is as short as possible with a sufficient cross-section area for the current level being used.

NOTE

- Note that the ammeter (RMS, peak) on the master unit will not display correctly if the flat cable used for parallel operation becomes disconnected during parallel or tracking operation.
- Ensure that the insulation on the load cable you use has good fire resistance.
- Ensure that the cables to the load input terminals on each PCZ1000A are as similar in length as possible.

1 Turn off the **POWER** switch.

2 Connect the cables to the load input terminals.

Referring to the connection diagram in Fig.3-8, connect the cables to the load input terminals on each unit (which must all be of the same model).

3 Connect the parallel operation connector.

Use the option flat cable (PC01-PCZ1000A) to connection between the **PARALLEL OUT** and **PARALLEL IN** connectors on each unit.

Procedure for Setting Master and Slave Units

- 1 Turn on the POWER switch on each unit.
Either turn on the POWER switch on all units at the same time or turn on the master unit first.

NOTE

- If the power to the slaves is turned on first, turn on the POWER switch on the master unit within 30 seconds of turning on the POWER switch on the slaves. An external alarm 2 occurs if this time is longer than 30 seconds.

- 2 Press the LOAD key to go to the load-off state.
- 3 Press SHIFT + I SET(CONFIG).
- 4 Press the ENTER key to select ">1:Norm /M/S".
- 5 Use the JOG/SHUTTLE dial to select "MASTER" or "SLAVE".

```
> 1: Norm/M/S
      MASTER
```

- 6 Use the ENTER key to select ">2: Para/Track".
- 7 Use the JOG/SHUTTLE dial to select "PARALLEL".
Selecting "PARALLEL" for parallel operation causes the total current from the master and slave units to be displayed on the ammeter display of the master unit.

```
> 2: Para/Track
      PARALLEL
```

- 8 On a slave unit, press the SHIFT+I SET (CONFIG) key or press the ESC key to exit CONFIG setting. On the master unit, proceed to the next step.
On the slave units, "P <<Slave>>" appears on the front panel display.

```
P      << Slave >>
```

- 9 Press the ENTER key to select ">3:Parallel Ope.".

10 Use the JOG/SHUTTLE dial to select the number of parallel units.

Up to five units (including the master) can be connected together for parallel operation. The current will not display correctly on the master unit if the actual number of units is different to the number specified here. Always take care to specify the actual number of connecting units. The following example is for two units.

```
> 3: Parallel Ope.  
      2
```

11 Press the ENTER key displays ">4: Calibration". If you do not want to calibrate the total current on the master unit, press the SHIFT + I SET (CONFIG) key or the ESC key to exit CONFIG setting.

When parallel operation is set, the number of units connected in parallel is displayed on the bottom left of the front panel display. The example below is for the case when two units are connected.

```
0.00Ar 0.0Ap 100.1V  
2 ISET 0.00A --
```

NOTE

- Although the set ranges for the current, power, and resistance are all increased on the master unit, the pre-setup values still appear on the display. When you carry out parallel operation by a mode except CP mode, be sure to change PSET value of the master unit to the required power value.
-

3.7.3 Tracking Operation

For tracking operation, the setting values specified on the master unit are also applied to the slave units, and any changes to the master settings also apply simultaneously to the slaves.

This function is useful for testing single-phase/three-wire or three-phase/three-wire AC power supplies. The current displays on the master and slaves indicate the current reading of each unit. Fig.3-10 shows connection example.

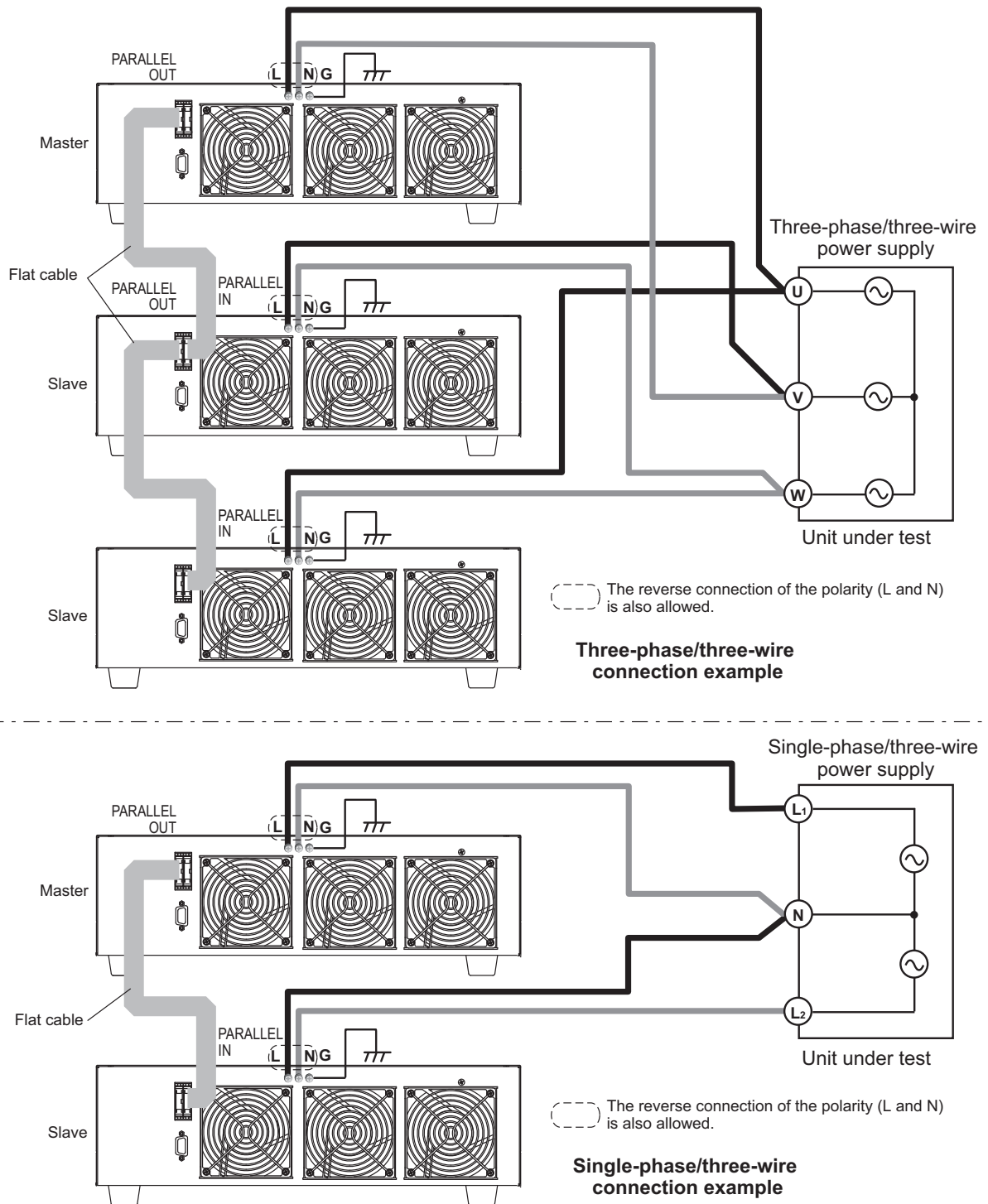

Fig.3-10 Tracking Operation Connection

Connecting Units for Tracking Operation

⚠ WARNING Risk of electric shock

- Turn off the **POWER** switch when you are touching the load input terminals, **PARALLEL IN** connector, or **PARALLEL OUT** connector. Also, re-attach the load input terminal cover after connecting the cables.
- Always fit the protective socket when not using the **PARALLEL IN** connector or **PARALLEL OUT** connector.

⚠ CAUTION Risk of damage to the PCZ1000A.

- Take care not to get the **PARALLEL IN** connector and **PARALLEL OUT** connector mixed up.
 - Ensure that the load cable is as short as possible with a sufficient cross section for the current level being used.
-

NOTE

- Ensure that the insulation on the load cable you use has good fire resistance.
 - Ensure that the cables to the load input terminals on each of the PCZ1000A are as similar in length as possible.
-

- 1 Turn off the **POWER** switch.
 - 2 Connect the cables to the load input terminals.
Referring to the connection diagram in Fig.3-10, connect the cables to the load input terminals on each unit (which must all be of the same model).
 - 3 Connect the parallel operation connector.
Use the option flat cable (PC01-PCZ1000A) to connection between the **PARALLEL OUT** and **PARALLEL IN** connectors on each unit.
-

Procedure for Setting Master and Slave Units

- 1 Turn on the **POWER** switch on each unit.
Either turn on the **POWER** switch on all units at the same time or turn on the master unit first.
-

NOTE

- If the power to the slaves is turned on first, turn on the **POWER** switch of the master unit within 30 seconds. An external alarm 2 occurs if this time is longer than 30 seconds.
-

- 2 Press the **LOAD** key to go to the load-off state.
 - 3 Press **SHIFT + I SET(CONFIG)**.
 - 4 Use the **ENTER** key to select ">1:Norm /M/S".
-

- 5 Use the JOG/SHUTTLE dial to select "MASTER" or "SLAVE".

```
> 1: Norm/M/S
      MASTER
```

- 6 Use the ENTER key to select ">2: Para/Track".

- 7 Use the JOG/SHUTTLE dial to select "TRACKING".

```
> 2: Para/Track
      TRACKING
```

- 8 Press the SHIFT + I SET (CONFIG) key or ESC key to exit CONFIG setting.

When tracking operation is set, "T" appears on the bottom left of the front panel display.

```
0.00Ar 0.0Ap 100.1V
T  ISET      5.00A  --
```

On the slave units, "T << Slave >>" appears on the front panel display.

```
0.00Ar 0.0Ap 100.1V
T  << Slave >>
```

3.7.4 Calibration of the Ammeter on the Master Unit During Parallel Operation

The ammeter of the PCZ1000A when used for parallel operation is calibrated at the shipment from the factory. However, the ammeter accuracy can be improved further by calibrating the instrument under the actual parallel operation conditions

Preparation for Calibration

- To minimize the measurement error due to startup drift, allow the current to flow for 30 minutes before starting the test. Also, maintain the ambient temperature at $23\text{ }^{\circ}\text{C} \pm 5\text{ }^{\circ}\text{C}$.

- Equipment

AC power supply: An AC power supply with adequate capacity to supply the combined requirements of all the instruments.

Output current (RMS): Number of units \times 10 A

Output current (peak): Number of units \times 40 A

Output voltage (RMS): 10 V

AC ammeter:

A meter with sufficient range to measure an RMS current of number of units \times 10 A and a peak current of number of units \times 40 A.

Accuracy 0.5 % or better, frequency: 45 Hz to 65 Hz.

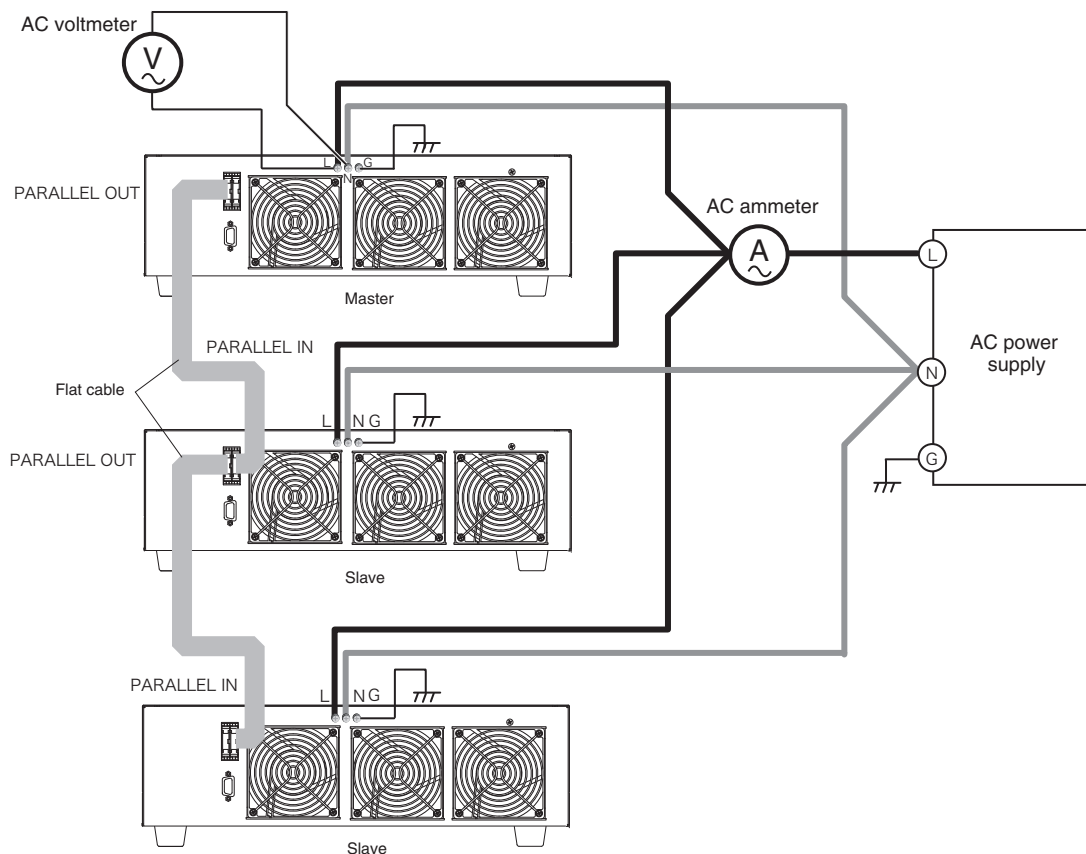

Fig.3-11 Wiring Diagram for Calibration

Calibration Procedure

If calibration is interrupted before being finished, the next calibration will be restarted from the same step where it left off.

- 1 Press the LOAD key to set the instrument to the load-off state.
- 2 Press SHIFT + I SET (CONFIG).
If "Norm/M/S" is not displayed, press the ENTER key to select ">3: Norm/M/S".
- 3 Use the JOG/SHUTTLE dial to select "MASTER".

```
> 1: Norm/M/S
      MASTER
```

- 4 Press the ENTER key to select ">2:Para/Track".
- 5 Use the JOG/SHUTTLE dial to select "PARALLEL".

```
> 2: Para/Track
      PARALLEL
```

- 6 Press the ENTER key to select ">3: Parallel Ope".
- 7 Use the JOG/SHUTTLE dial to set the "number of units".(This example sets the number of units to two.)

```
> 3: Parallel Ope.
      2
```

- 8 Press the ENTER key to display ">4: Calibration".
This changes the PCZ1000A to calibration mode. Proceed to the calibration procedure.

■ Calibrating the offset and gain for the total current (RMS)

- 1 Press the I SET key to display "IRS OFFS XXXXX".
XXXXXX is the RMS offset value.
- 2 Press the LOAD key to change the instrument to the load-on state.
- 3 Use the JOG/SHUTTLE dial to set the offset value (variable range: -7000 to 1000) on the front panel display to the value on the externally connected AC ammeter (RMS meter).

-
- 4 Press the A key to display " GAIN XXXXX".
XXXXX is the RMS gain. The display switches between "IRS OFFS XXXXX" and "IRS GAIN XXXXX" each time the A key is pressed.
 - 5 Use the JOG/SHUTTLE dial to adjust the gain value (variable range: 31000 to 39000) on the front panel display to the value on the externally connected AC ammeter (RMS meter).
As the offset and gain are mutually dependent, it is recommended that you adjust each in turn.
 - 6 After calibrating the offset and gain, press the MEM key to display "SAVE?".
If you want to stop calibration before finishing, press the MEM key to display "SAVE?" and then press the ESC key.
 - 7 Press the ENTER key.
The calibration data is written to internal memory in the PCZ1000A.

NOTE

- If the calibration can not be performed for the offset value and the gain value within the variable range, please confirm whether the POWER switch of the slave unit is turned in the "off" position. In case the POWER switch of the slave unit is not in the "off" position, contact your Kikusui distributor/agent.
-

■ Calibrating the offset and gain for the total current (peak)

- 1 Press the R SET key to display "R OFFS XXXXX".
XXXXX is the peak offset value.
- 2 Press the LOAD key to change the PCZ1000A to the load-on state.
- 3 Use the JOG/SHUTTLE dial to set the offset value on the front panel display to the value on the externally connected AC ammeter (peak meter).
- 4 Press the A key to display "IPS GAIN XXXXX".
XXXXX is the RMS gain. The display switches between "IPS OFFS XXXXX" and "IPS GAIN XXXXX" each time the A key is pressed.
- 5 Use the JOG/SHUTTLE dial to adjust the gain value on the front panel display to the value on the externally connected AC ammeter (peak meter).
As the offset and gain are mutually dependent, it is recommended that you adjust each in turn.
- 6 After calibrating the offset and gain, press the MEM key to display "SAVE?".
If you want to stop calibration before finishing, press the MEM key to display "SAVE?" and then press the ESC key.
- 7 Press the ENTER key.
The calibration data is written to internal memory in the PCZ1000A. This completes calibration.

3.7.5 Alarms During Parallel and Tracking Operation

External alarm 1

If an external alarm 1 occurs during parallel or tracking operation, a buzzer sounds, an error message is displayed, and all PCZ1000As go to the load-off state.

The alarm message from the protection function is displayed on the PCZ1000A on which the alarm occurred, and all the other PCZ1000As display:

"*ALARM EXT1*".

When an alarm occurs, the buzzer on the PCZ1000A on which the alarm occurred sounds at shorter intervals than the other PCZ1000As.

NOTE

- Turning off the POWER switch on the master unit or any of the slave units when no alarm is present causes an external alarm 1 to occur on all the other units.

External alarm 2

If an external alarm 2 occurs during parallel or tracking operation, a buzzer sounds, an error message is displayed, and the PCZ1000A on which the alarm occurred goes to the load-off state.

The display on the PCZ1000A on which the alarm occurred is:

"*ALARM EXT2*"

NOTE

- Note that, if the flat cable used to connect PCZ1000As in parallel becomes disconnected during parallel or tracking operation, the ammeter (rms and peak) on the master unit will not read correctly.

Clearing alarms

Pressing the SHIFT + ESC (ALM CLR) key clears the alarm, a new alarm will be generated if the cause of the alarm still exist.

Pressing the SHIFT + ESC (ALM CLR) key on the master unit clears the alarm on the PCZ1000A other than the one that generated the original alarm.

To clear the alarm on the PCZ1000A where it was generated, press SHIFT + ESC (ALM CLR) on that unit.

3.7.6 Returning to Standalone Operation

To return to standalone operation after parallel or tracking operation, turn off the POWER switches on each unit and then unplug the flat cable.

- 1 Press SHIFT + I SET(CONFIG) to select ">1:Norm/M/S".
If this is not displayed on the screen, press the ENTER key several times until it appears.
- 2 Use the JOG/SHUTTLE dial to select "NORMAL".

- 3 Press SHIFT + I SET (CONFIG) or the ESC key to exit CONFIG setting.

NOTE

- When setting a slave unit back to "NORMAL", perform the Step 1 to Step 3 operations within 30 seconds. An external alarm 2 occurs if this procedure is not performed within 30 seconds.

3.8 Factory Default Settings

Hold down the MEM key as you turn on the POWER switch and do not release until after about 8 seconds. First, the model name and firmware version are displayed, then the screen shown in Fig.3-12 appears for approximately 2 seconds and the instrument is set back to its factory default settings.

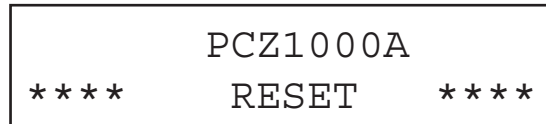

Fig.3-12 Completion Screen When Restoring Factory Default Settings

The table below lists the factory default settings. The A, B, and C preset memories are also restored to their factory default settings.

Table3-3 Factory Default Settings

Setting		Setting Value (Panel Setting)
Current limit		0 A
Resistance limit		1000.0 Ω
Power limit		1050 W
Crest factor		1.4
Operation mode		CC mode
CR mode range		H
Crest factor function on/off		OFF
ABC preset memory		Above settings for each mode
Load on/off		Load-off
CONFIG	1. Norm/M/S	NORMAL
	2. Para/Track	PARALLEL
	3. Parallel Ope.	2
	4. Calibration	Push [I SET] (fixed)



Remote Control

This chapter describes how to program the remote control features of the PCZ1000A using an external device such as a personal computer. The explanation covers the command syntax, details of each command, and the registers.

4.1 Overview of Remote Control

As an alternative to using the front panel, the PCZ1000A can also be operated remotely via an RS-232C interface.

4.1.1 RS232C Interface

RS232C connection

The RS232C port on the PCZ1000A is a standard D-sub 9-pin male connector. Check that the POWER switches of the PCZ1000A and the computer are turned off, and connect the PCZ1000A to the computer using a standard cross cable (null modem cable). Use a D-sub 9-pin female-to-female AT type cross cable. Fig.4-1 shows the connector pin arrangement.

Because the PCZ1000A does not use hardware handshaking, the DTR(4) / DSR(6) and RTS(7) / CTS(8) wires are not necessary to be connected.

Plug the RS232C cable into the RS232C connector on the rear panel.

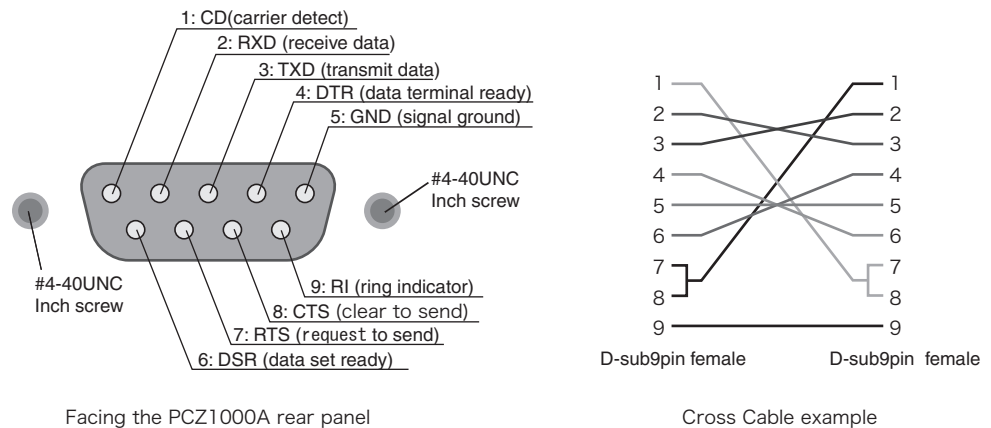

Facing the PCZ1000A rear panel

Cross Cable example

Fig.4-1 9-Pin AT Type Connector

Protocol

Table 4-1 shows the RS232C protocol.

Table 4-1 RS232C Protocol

Item	Setting
Connector	9-pin D-sub terminal on the rear panel
Baud rate	Fixed at 9,600 bps
Data	Fixed at 8 bits
Stop	Fixed at 2 bits
Parity	Fixed at none
Flow (X-flow control)	XON/XOFF

Break signal

The break signal functions as a substitute for the IEEE488.1 dcl/sdc (Device Clear, Selected Device Clear) message.

RS232C communications

Use X-flow control for RS232C communication. DC (device control) codes are used as control codes. Transmission and reception may not work correctly if X-flow control is not used.

Table 4-2 DC Codes

Code	Function	ASCII Code
DC1	Request to send	11H
DC3	Transmission stop request	13H

Transmission control from the PC to the PCZ1000A.

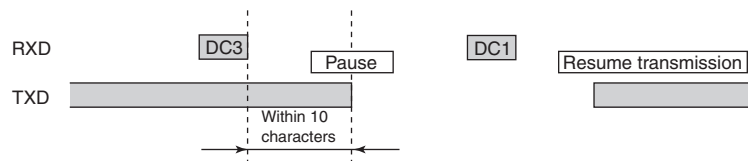

The RS232C terminal must pause transmission within 10 characters after receiving DC3.

Transmission control from the PCZ1000A to the PC.

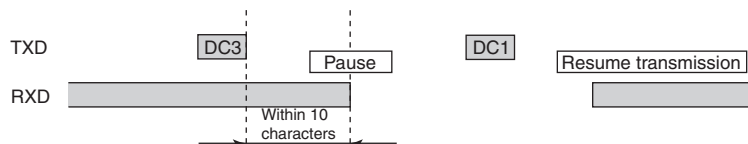

The PC must pause transmission within 10 characters after receiving DC3.

Fig.4-2 Transmission Control Between the PC and PCZ1000A

4.2 Programming Format

This section describes the general programming format.

Program message terminator

The PCZ1000A can receive any of the three types of program message terminators specified below.

- CR
- LF
- CR + LF

4.2.1 Program Messages

The program messages sent from the RS-232C terminal to the PCZ1000A are as follows:

Command message

This message activates the PCZ1000A. The message is an ASCII-code character string consisting of a header, data, and other information. (For the header and data, see 4.3.1, *X* Program Header and Program (Response) Data.”

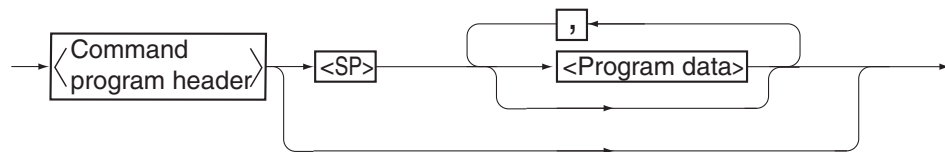

Query message

This message requests information from the PCZ1000A. The message is an ASCII-code character string consisting of a header with a question mark (?), data, and other information.

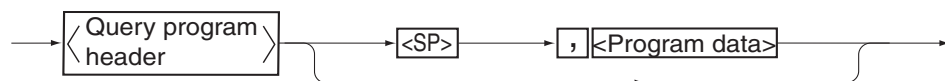

The PCZ1000A does not support use of the compound message delimiter ";;"

Multiple messages

The messages contain multiple program messages and query messages.

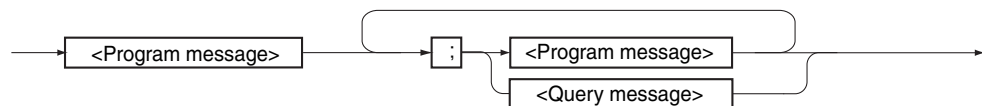

Response Message

A response message is information returned from the PCZ1000A to the computer in response to a query message. The message is an ASCII-code character string consisting of a header, numerical data, and other information. It is composed entirely of upper-case characters. (To request that a header be included, the HEAD command must be set to 1.)

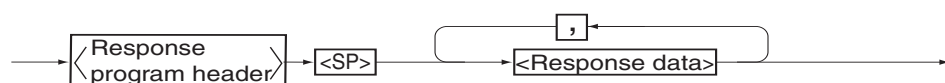

4.3 Device Messages

This section describes the contents of device messages.

4.3.1 Program Header and Program (Response) Data

Program header

The program header is an ASCII-code character string. This manual expresses it in upper-case characters, but lower-case characters may be used as well. Do not enter other characters, such as a space between the ASCII-code characters.

Program (response) data

This is an argument following the program header, and its format is defined individually for each program header.

■ Decimal program data

Integers and decimals (such as 8 and 1.25). The units that can be decoded are as follows:

Current: KA, A or MA (Default: "A")

Power: KW, W or MW (Default: "W")

Resistance:

KOHM, OHM or MOHM (Default: "OHM")

CREST FACTOR No unit

Where K: 10^3 , M: 10^{-3}

Figures to the right of the least significant digit are rounded down.

- The PCZ1000A does not support the use of exponents.
- Note that the PCZ1000A discards figures to the right of the least significant digit, rather than rounding them off.
- Number of significant digits

I SET value: Two decimal places

P SET value: Least significant digit of integers

R SET value: Five digits in total

CREST FACTOR value: One decimal place

NOTE

- The resolution of the resistance limit setting is in units of S (siemens). Accordingly, the specified resistance limit setting may not be set exactly to the setting value. In this case, the next highest valid resistance setting is used. For example, if 251Ω (3.98 mS) is set via remote control when the H range is set, the actual setting will be 333.33Ω (3 mS).

■ **Numeric program data**

"1" and "0" are treated as symbols corresponding to "ON" and "OFF". Signs (+, -) and decimal points cannot be used and will result in an error.

■ **Character program data**

This is character-string data such as "ON" and "OFF."

4.3.2 Configuration of Device Messages

Basic Messages

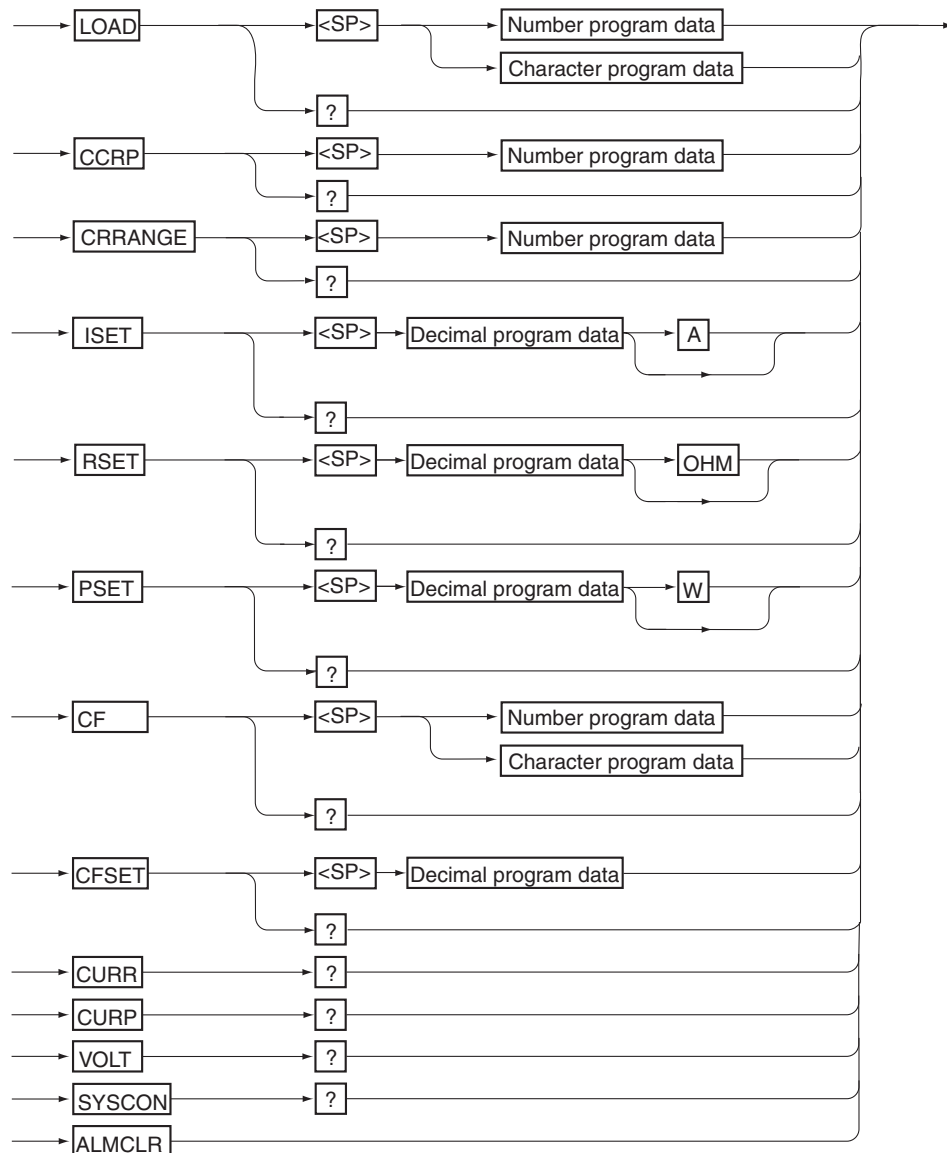

Header Name	Data	Operation
LOAD	<u>0(OFF)</u> ^{*1}	Turns the load (current) off
	1(ON)	Turns the load (current) on
LOAD?	-	Returns "0, 1"
CCRP	<u>1</u>	Enables CC mode
	2	Enables CR mode
	3	Enables CP mode
CCRP?	-	Returns "1, 2, 3"
CRRANGE	0	Sets the CR-mode range to "L"
	<u>1</u>	Sets the CR-mode range to "H"
CRRANGE?	-	Returns "0, 1"
ISET	<u>0 A</u> to 10.50 A ^{*2}	Sets an ISET value
ISET?	-	Returns an ISET value
RSET	H range: 0.9000 Ω to <u>1000.0 Ω</u> ^{*2}	Sets an RSET value
	L range: 9.0000 Ω to 10000 Ω ^{*2}	
RSET?	-	Returns an RSET value
PSET	45 W to <u>1050 W</u> ^{*2}	Sets an PSET value
PSET?	-	Returns an PSET value
CF	<u>0(OFF)</u>	Disables the crest factor
	1(ON)	Enables the crest factor
CF?	-	Returns "0, 1"
CFSET	<u>1.4</u> to 4.0	Sets a CREST FACTOR value
CFSET?	-	Returns a CREST FACTOR value
CURR?	-	Returns the RMS value of the input current
CURP?	-	Returns the peak value of the input current
VOLT?	-	Returns an input voltage value
SYSCON?	-	Returns the following settings: ^{*3} NORMAL/MASTER/SLAVE, PARALLEL/TRACKING, Number of parallel units
ALMCLR	-	Clears the alarm

*1 Default values are shown underlined.

*2 The value is different if in parallel operation.

*3 Example: Returns NORMAL, 0, 0 when standalone operation. Returns SLAVE, PARALLEL, 0 when in slave mode in parallel operation.

Header Name	2 Units	3 Units	4 Units	5 Units
ISET	0 A to 21.00 A	0 A to 31.50 A	0 A to 42.00 A	0 A to 52.50 A
RSET	H range: 0.4500 Ω to 500.00 Ω	H range: 0.3000 Ω to 333.33 Ω	H range: 0.2250 Ω to 250.00 Ω	H range: 0.1800 Ω to 200.00 Ω
	L range: 4.5000 Ω to 5000.0 Ω	L range: 3.0000 Ω to 3333.3 Ω	L range: 2.2500 Ω to 2500.0 Ω	L range: 1.8000 Ω to 2000.0 Ω
PSET	90 W to 2100 W	135 W to 3150 W	180 W to 4200 W	225 W to 5250 W

System Messages

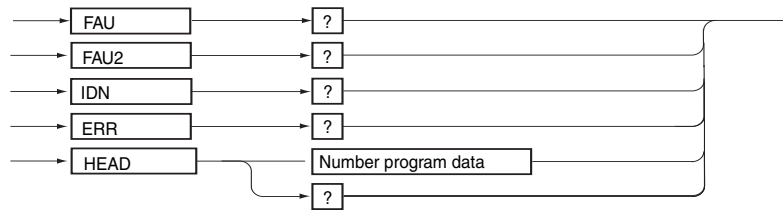

Header Name	Data	Operation
FAU?	-	Returns the value of the fault register
FAU2?	-	Returns the value of fault register 2
IDN?	-	Returns the model number and version number
ERR?	-	Returns an error register value
HEAD	1(ON)	Specifies that headers are to be attached to response messages
	0(OFF)	Specifies that headers are not to be attached to response messages
HEAD?	-	Returns "0, 1"

Communication Settings and Control Codes

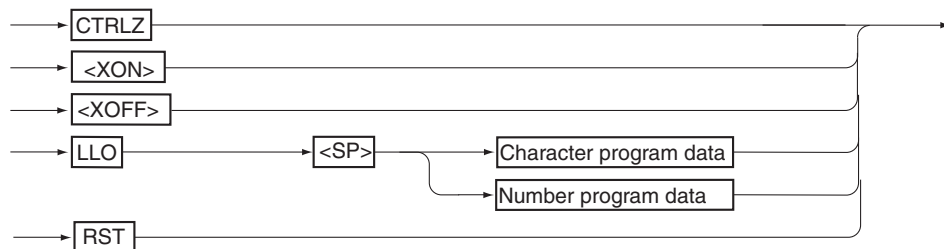

Header Name	Data	Operation
CTRLZ	-	Returns the control Z code (1Ah)
<XON> (11h)	-	Resumes RS-232C transmission (See "RS232C communications" on page 4-3.)
<XOFF> (13h)	-	Halts RS-232C transmission
LLO	1(ON)	Sets local lockout
	0(OFF)	Cancel local lockout
LLO?	-	Returns "0, 1"
RST	-	Resets to the factory default settings (See "Factory Default Settings" on page 3-34. Note, however, that the configuration settings remain unchanged.)

NOTE

- The instrument has no messages for controlling the preset memory function.

4.4 Assignment of Register Bits

A bit becomes "1" when the current state is "true".

The returned value is the sum (bitwise AND) of the bit decimal values.

Example:

The value returned when both the overheating protection function [4] and overpower protection function [16] are activated is:

$$4 + 16 = 20$$

where 20 is response data.

Fault Register

Bit	Decimal Value	Status of Fault Register	
0	1	Overvoltage protection triggered	(OVP)
1	2	Overcurrent protection or peak overcurrent protection triggered	(OCP, POCP)
2	4	Overheat protection triggered	(OHP)
3	8	Internal circuit protection triggered	(FUSE BRK)
4	16	Overpower protection triggered	(OPP)
5	32	CP-range operation	(CP)
6	64	CR-range operation	(CR)
7	128	CC-range operation	(CC)

The bits in this register are latched when the corresponding status is present and cleared after the register is read to provide the response message to an "FAU?" request. To determine the present status, send "FAU?" to clear the register and then send "FAU?" again to retrieve the present status.

Fault Register 2

Bit	Decimal Value	Status of Fault Register 2	
0	1	External alarm 1 triggered	(EXT1 ALARM)
1	2	-	-
2	4	-	-
3	8	-	-
4	16	-	-
5	32	-	-
6	64	-	-
7	128	-	-

The bits in this register are latched when the corresponding status is present and cleared after the register is read to provide the response message to an "FAU2?" request. To determine the present status, send "FAU2?" to clear the register and then send "FAU2?" again to retrieve the present status.

NOTE

- External alarm 2 events are not stored in any fault register.

Error Register

Bit	Decimal Value	Status of Error Register
0	1	Error in program header area
1	2	Error in data other than program header
2	4	Error due to data out of range
3	8	Received message is not currently enabled
4	16	Buffer full: CR or CF was not received within 80 characters
5	32	-
6	64	-
7	128	-

The bits in this register are latched when the corresponding error occurs and cleared after the register is read to provide the response message to an "ERR?" request.

Communication Command Errors

If an error occurs in a communication command, the following message is displayed on the lower part of the front panel display for 2 seconds.

Error	Displayed Message
Error in program header	HEADER ERROR
Error in data other than program header	DATA ERROR
Error due to data out of range	RANGE ERROR
Received message is not currently enabled	INVALID MESSAGE
Buffer full: CR or CF was not received within 35 characters	BUFFER FULL



Maintenance and Calibration

This chapter describes the maintenance procedures including cleaning, inspection, and calibration.

5.1 Cleaning and Inspection

Periodic inspection is essential to maintain the initial performance of the PCZ1000A over an extended period.

-
- ⚠ WARNING** • Risk of electric shock. Before performing maintenance work, be sure to turn off the POWER switch and disconnect the power cord.
-

Inspecting the Power Cord

Check that there is no wear or damage to the insulation on the power cord.

-
- ⚠ WARNING** • Any deterioration of the power cord can result in electric shock or fire. Stop using the cable immediately if it is damaged.
-

Please contact your local Kikusui agent or distributor if you wish to purchase accessories or options.

Cleaning the Panel

If the panel needs cleaning, gently wipe using a soft cloth with water-diluted neutral detergent.

-
- ⚠ CAUTION** • Do not use volatile chemicals such as benzene or thinner as they may discolor the surface, erase printed characters, cloud the display, and so on.
-

Replacing the Backup Battery

The PCZ1000A has an internal battery used to backup the panel settings when the power is turned off. If the panel settings when the instrument is turned on are not the same as when it was last turned off, the battery may be dead.

Although the life of the battery depends on the operating condition, it is typically to last for about three years after purchase. To replace the battery, please contact your Kikusui agent or distributor.

Cleaning the Dust Filter

The dust filter sheet is installed on the inside of the louver on the front panel. Periodically clean the filter to prevent clogging.

CAUTION

- **Clogged filters hinder cooling inside the PCZ1000A which can cause malfunctions and shorten the service life.**
- When the PCZ1000A is in operation, air is sucked through the dust filter to cool the inside. If moisture is present in the dust filter, the temperature or humidity inside the PCZ1000A increases and may cause a malfunction.

Removing and reattaching the louver

- 1 Remove the louver from the front panel.

To remove the louver, push down on the lugs at its base, then pull the louver toward you.

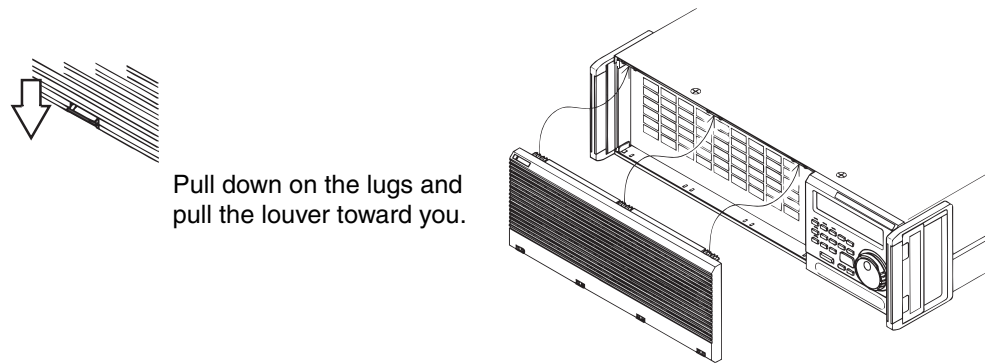

Fig.5-1 Removing the Louver

- 2 Clean the front panel louver

Use a vacuum cleaner to remove any dust or dirt from the dust filter. If particularly dirty, clean with water-diluted neutral detergent and then leave to fully dry.

Reattaching the louver

- 3 Align the projections at its upper section with the recessed parts of the instrument.
- 4 Fit the lower section onto the PCZ1000A.
- 5 Push up the lugs.

5.2 Calibration

The PCZ1000A was fully calibrated before shipment from our factory. However, recalibration may be necessary after long-term use.

Contact your Kikusui agent or distributor to arrange for calibration.





Specifications

This chapter gives the specifications and dimensions of the PCZ1000A.

6.1 Specifications

Unless specified otherwise, the specifications are defined by the following terms and conditions.

- The warm-up time is 30 minutes (with current flowing).
- Temperature: 20 °C to 30 °C
- Humidity: 20 %rh to 85 %rh
- rdng : Indicates the reading.
- set: Indicates the setting.
- FS: Indicates the full scale.

Basic performance

Input rating (AC)		
Operation voltage ^{*1}	14 Vrms to 280 Vrms	
	20 Vpeak to 400 Vpeak	
Maximum current ^{*2}	10 Arms	
	40 Apeak	
Maximum power ^{*3}	1000 W	
Frequency	45 Hz to 65 Hz	
Minimum operation start voltage ^{*4}	3 Vpeak	
Constant-current (CC) mode ^{*5}		
Setting range	0 Arms to 10 Arms	
Setting accuracy ^{*6}	Within ± (1 % of set + 0.1 A)	
Setting resolution	10 mArms	
Stability	Line variations ^{*7}	Within 10 mArms
	Input-voltage variations ^{*8}	Within 100 mArms
Temperature coefficient (at the rated current)	200 ppm/°C(typical)	
Constant-resistance (CR) mode ^{*9}		
Setting range	H range (Full current at 10 V)	1 Ω to 1 kΩ
	L range (Full current at 100 V)	1 S to 1 mS ^{*10}
Setting resolution	H range (Full current at 10 V)	10 Ω to 10 kΩ
	L range (Full current at 100 V)	0.1 S to 0.1 mS ^{*10}
Setting accuracy (in current terms) ^{*6, *11}	Within ± (2 % of set + 0.2 A)	
Stability Input-voltage variations ^{*12}	Within ± 10 %	
Constant-power (CP) mode ^{*13}		
Setting range	50 W to 1000 W	
Setting accuracy ^{*6, *14}	Within ± 5 % of set	
Setting accuracy	1 W	
Input-voltage variations ^{*15}	Within ± 5 %	
Crest-factor (C.F) function ^{*16}		
Setting range	1.4 to 4.0	
Resolution	0.1	
Ammeter (RMS display mode)		
Number of display digits (full scale)	10.00 Arms	
Accuracy ^{*6}	Within ± 1 % of FS	
Ammeter (peak display mode)		
Number of display digits (full scale)	40.0 Apeak	
Accuracy ^{*6}	Within ± 2 % of FS	

Voltmeter	
Number of display digits (full scale)	300.0 Vrms
Accuracy* ⁶	Within $\pm 1\%$ of FS
Protection function* ¹⁷	
Peak overcurrent protection (POCP)* ¹⁸	Approx. 48 A _{peak}
Overcurrent protection (OCP)* ¹⁹	Approx. 11.5 Arms
Overvoltage protection (OVP)* ¹⁸	Approx. 470 V _{peak}
Overpower protection (OPP)	Approx. 1150 W
Overheat protection (OHP)* ²⁰	—
Internal circuit protection(FUSE BRK)	Internal fuse blown
External alarm 1 (EXT1)	Another unit has detected an alarm during parallel or tracking operation.
External alarm 2 (EXT2)	Alarm detected when the PC01-PCZ1000A flat cable comes unplugged during parallel or tracking operation (only on slave units that become disconnected from the master).
Input power (AC)	
Voltage range (nominal value)* ²¹	90 Vrms to 110 (100) Vrms
	108 Vrms to 132 (120) Vrms
	180 Vrms to 220 (200) Vrms
	216 Vrms to 250 (240) Vrms
Frequency	50 Hz/60 Hz
Power consumption (apparent power)	MAX 220 VA

- *1. Input-voltage range in which the rated input current can flow.
- *2. For an input voltage of 100 Vrms or greater, the maximum current is derated to the rated input power (1000 W).
- *3. For an input voltage of 100 Vrms or less, the maximum power is limited by the rated input current (10 Arms).
- *4. Minimum input voltage at which the input current starts to flow
- *5. The input-current waveform does not change with changes in the input-voltage waveform. The RMS value of the input current is kept constant (response rate: approximately 1 s). (Response rate: Time required to reach $\pm 10\%$ of the steady value (value reached 5 seconds or more after state change))
- *6. At temperature(23 ± 5 °C)
- *7. Changes in the input current when variations in the rated-voltage range are given at an input voltage of 100 Vrms and an input current of 10 Arms, based on the nominal value of the input line voltage.
- *8. Changes in the input current when the input voltage is changed from 10 Vrms to 280 Vrms at an input current of 3.57 Arms (rating at an input voltage of 280 Vrms).
- *9. The input-current waveform does not change with changes in the input-voltage waveform. This mode results in an input current (RMS value) that is proportional to the RMS value of the input voltage (response rate: approximately 1 s).
- *10. S represents the unit of conductance (siemens).
Conductance [S] = 1/resistance value [Ω]
Conductance [S] \times input voltage [V] = load current [A]
- *11. At an input voltage of 100 Vrms.
- *12. Changes in the resistance value when the input voltage is varied from 10 Vrms to 100 Vrms at an input current of 0.5 A or more.
- *13. The input-current waveform does not change with changes in the input-voltage waveform. This mode results in an input current (RMS value) that is inversely proportional to the RMS value of the input voltage (response rate: approximately 1 s).
- *14. At an input voltage of 100 Vrms
- *15. Changes in the power value when the input voltage is varied from 10 Vrms to 100 Vrms.
- *16. Varies the angular width of the current at the approximate input-voltage peak, based on a sinusoidal current waveform.
- *17. Turns off the LOAD key when the protection function is activated.
- *18. Turns off the LOAD key within 20 ms.
- *19. Turns off the LOAD key within 3 ms.
- *20. Detects the internal-heat-sink surface temperature to turn off the LOAD key.
- *21. Selectable by Switch position.

General specifications

Isolation voltage		± 500 Vdc
Withstand voltage	Primary side to case	1 500 Vac for 1 minute
	Primary side to load input terminals	1 500 Vac for 1 minute
	Load input terminals to case	500 Vac for 1 minute
Insulation resistance	Primary side to case	1 000 Vdc at 20 MΩ or more
	Primary side to load input terminals	1 000 Vdc at 20 MΩ or more
	Load input terminals to case	1 000 Vdc at 20 MΩ or more
Temperature and humidity ranges	Operating temperature range	0 °C to 40 °C (32 °F to 104 °F)
	Operating humidity range	20 %rh to 85 %rh (no condensation)
	Storage temperature range	-25 °C to 70 °C (-13 °F to 158 °F)
	Storage humidity range	90 %rh and below (no condensation)
Electromagnetic Compatibility (EMC) ^{*1}		Complies with the requirements of the following directives and standards. EMC Directive 2004/108/EC EN 61326-1 (Class A ^{*2}) EN 55011 (Class A ^{*2} , Group 1 ^{*3}) EN 61000-3-2 EN 61000-3-3 Applicable condition All of the wires and wires connected to the PCZ1000A are less than 3 m in length.
Safety ^{*1}		Complies with the requirements of the following directives and standards. Low Voltage Directive 2006/95/EC EN 61010-1 (Class I ^{*4} , Pollution degree 2)
Dimensions (case)		430 W x 400 D x 128 H mm (16.93 W x 15.75 D x 5.04 H inch)
Weight		Approx. 22 kg
Accessories	Power cord	1 pc.
	Spare fuse	3 pcs.
	Operation manual	1 pc.

- *1. Applies only to models that have CE marking on the panel. Not applicable to custom order models.
- *2. This is a Class A equipment. This product is intended for use in an industrial environment. This product may cause interference if used in residential areas. Such use must be avoided unless the user takes special measures to reduce electromagnetic emissions to prevent interference to the reception of radio and television broadcasts.
- *3. This is a Group 1 equipment. This product does not generate and/or use intentionally radio-frequency energy, in the form of electromagnetic radiation, inductive and/or capacitive coupling, for the treatment of material or inspection/analysis purpose.
- *4. This is a Class I equipment. Be sure to ground this product's protective conductor terminal. The safety of this product is only guaranteed when the product is properly grounded.

Interface

RS232C	Complies with EIA232D, circuit common is insulated from the load input terminals (chassis potential)	
	Connector	D-SUB 9-pin connector (male) ^{*1}
	Baud rate	9600 bps (fixed)
	No. of data bits	8 bits (fixed)
	No. of stop bits	2 bits (fixed)
	Parity bit	None (fixed)
	Flow control	XON/XOFF

*1. Use a cross cable (null modem cable).

6.2 Dimensions

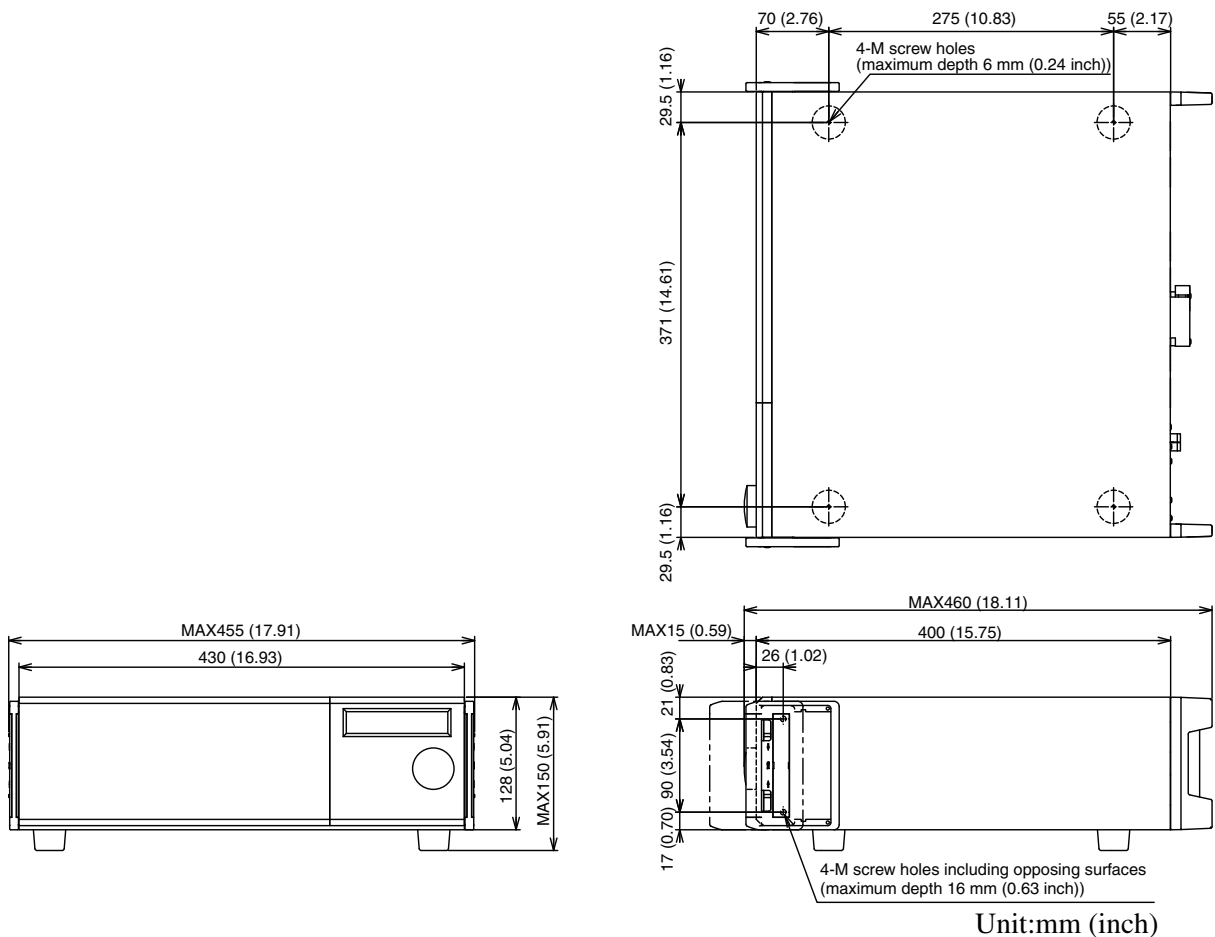
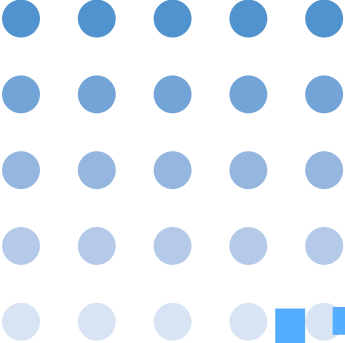

Fig.6-1 PCZ1000A outline drawing





Appendix

The appendix contains the basic operating modes, operating range, and troubleshooting.

A.1 Explanation of Operating Functions

A.1.1 Operating Functions

Operating Range

The operating range of the PCZ1000A is limited by the rated current, rated voltage, and rated power. The PCZ1000A can only be operated within the range indicated by the shaded area in the figure below. Note that rated current flow cannot be achieved, so if the input voltage is less than 20 V_{peak} (approximately 14 V_{rms}), the various specification characteristics will not be satisfied in this case. Moreover, input-voltage frequency synchronization cannot be achieved in this case and this may cause an extremely large distortion in the current waveform. With a low input voltage, the current waveform distortion becomes large. This distortion also becomes large for light loads for which the input voltage is high and the input current is low.

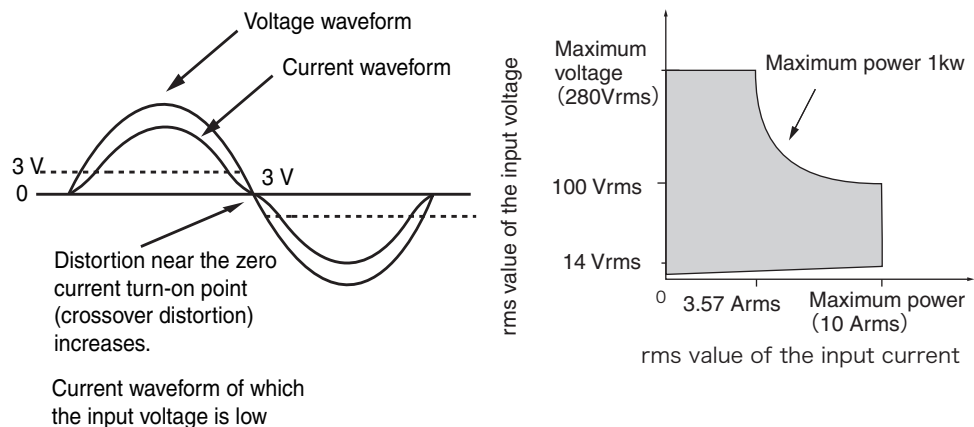

Fig.A-1 Operating Range

Differences Between DC and AC Loads

In general, a constant-current load always maintains current flow at a constant level, regardless of the applied voltage. DC loads operate in this way in constant-current mode.

For AC loads, if it operates in the way mentioned above, the current waveform becomes square (rectangular) regardless of the waveform of the applied voltage, which differs from a realistic AC load in that the polarity is inverted with the current kept constant. The PCZ1000A controls the RMS value of the current to ensure that the load current always has a sinusoidal waveform (except for the crest factor function). That is, when the voltage is constant and the waveform is sinusoidal, the PCZ1000A acts as a purely resistive load.



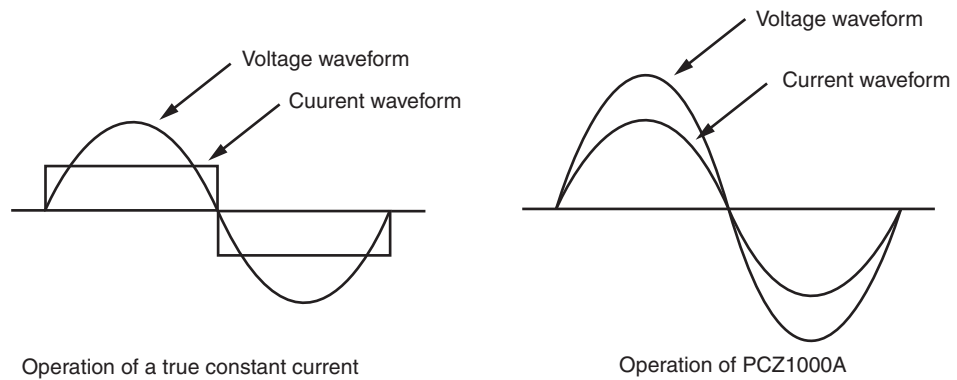

Fig.A-2 Differences in Operation

Crest factor function

The PCZ1000A varies the crest factor (CF = peak/rms; see the definition below) by changing the angular width (using the 90° and 270° peak values) of the current waveform. In this case, the current waveform is similar to a capacitor-input fullwave rectified waveform. (In a strict sense, however, it contains different harmonic components.)

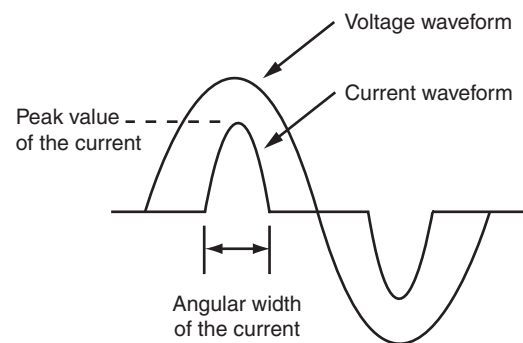

Fig.A-3 Crest factor function

DESCRIPTION

- Definition of basic alternating current terms

- Root-mean-square value, X (rms)

Square root of the average of the sum of a given squared number of the square of the instantaneous value (value X (t) at time "t") on the alternating-current waveform (voltage or current)

$$X = \sqrt{\frac{1}{T} \int_0^T [X(t)]^2 dt} \quad \text{Where T is one cycle of alternating current}$$

- Apparent power, VA

Product of the root-mean-square value of the voltage, V_{rms}, and current, I_{rms}
 $VA = V_{rms} \times I_{rms}$

- (Active) power, P (W)

Mean value of the product (instantaneous power p (t)) of the instantaneous value of the voltage (v) and that of the current (i)

$$P = \frac{1}{T} \int_0^T p(t) dt$$

- Crest factor (CF)

Ratio of the peak (crest) value of the voltage or current to its RMS value
 $CF = X_{peak}/X_{rms}$

A.1.2 Explanation of Operating Mode

Constant-Current (CC) Mode

In Constant-current (CC) mode, it maintains a constant current regardless of changes in the voltage.

The PCZ1000A operates as a constant-current load as shown in Fig.A-4 within the operating range shown in Fig.A-1. The RMS value of the input current (I) is maintained at the specified value regardless of changes in the input voltage.

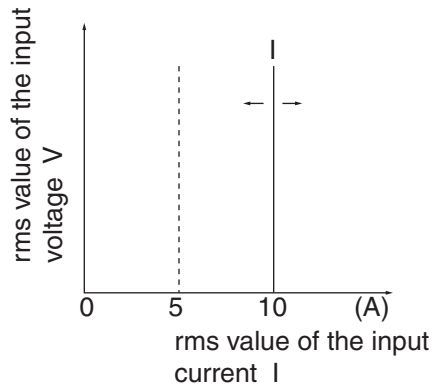

Fig.A-4 CC Mode

Transition points in CC mode operation

In Fig.A-5 below, the line A-B represents operation in CC mode and the line B-C represents operation in CP mode. As the RMS value of the input voltage (V_1) increases, the operating point of the PCZ1000A moves upwards from point A in CC mode. Operation changes to CP mode when the operating point reaches point B. Further increases in V_1 cause the current to decrease (see the above explanation of CC mode operation). When the operating point is on line 0-A, the internal PCZ1000A senses as if it were operating in CC mode.

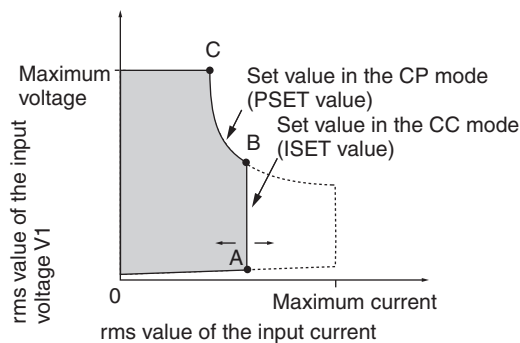

Fig.A-5 Transition Points in CC Mode Operation

Constant-Resistance (CR) Mode

In constant-resistance (CR) mode operation, the current flow is proportional to changes in the voltage.

The PCZ1000A operates as a resistive load as shown in Fig.A-6, within the range shown in Fig.A-1. If the input voltage changes, the current flow changes accordingly based on the specified resistance R, such that RMS input voltage/RMS input current = resistance.

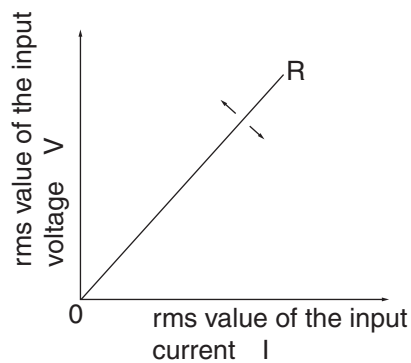

Fig.A-6 CR Mode

Transition points in CR mode operation

In Fig.A-7 below, the line F-G represents operation in CR mode, the line G-H represents operation in CC mode, and the line H-I represents operation in CP mode. As the RMS value of the input voltage (V_1) increases, the operating point of the PCZ1000A in CR mode starts from point F, then changes to operation in CC mode on reaching point G. As the voltage increases further to reach point H, the PCZ1000A operation changes again to CP mode (see the above explanation of CR mode operation). Note that, depending on the PSET and RSET values, the operating point may change directly from CR mode to CP mode.

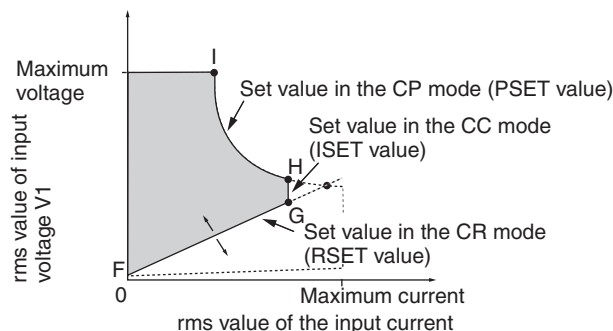

Fig.A-7 Transition Points in CR Mode Operation

Constant-Power (CP) Mode

In constant-power (CP) mode, the current flow is controlled to maintain constant power dissipation in the load.

The PCZ1000A operates as a constant-power load, as shown in Fig.A-8 load within the range shown in Fig.A-1. If the RMS input voltage increases, the PCZ1000A reduces the RMS current flow accordingly to keep the apparent power ($P = V \times I$) constant. In Fig.A-8, $P = V_2 \times I_2 = V_3 \times I_3$.

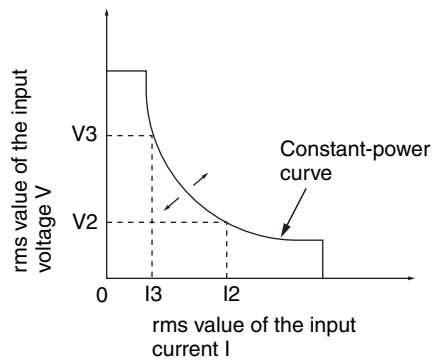

Fig.A-8 CP Mode

A.2 Troubleshooting

This section lists countermeasures for the troubleshooting. If you have a problem, refer to this list to check whether it matches any of the typical symptoms listed. In some cases, the problem can be solved easily.

 page 3-34

If none of the items apply to your case, we recommend that you initialize the PCZ1000A to the factory default settings (this clears the memory contents). If this does not correct the problem, contact your Kikusui agent or distributor.

The display remains blank after the POWER switch is turned on.

What to Check	Result	Possible Causes and Countermeasures	 Page
Is the voltage at the power supply (AC) input equal to the correct rated voltage?	No	The power cable is broken. Replace with a new power cable.	2-8
	Yes	The instrument is faulty Stop using the instrument and arrange for it to be repaired.	-
Is a fuse blown?	Yes	Replace with a spare fuse. If the fuse blows again, arrange to have the instrument repaired.	2-8

The display is dark after the POWER switch is turned on.

What to Check	Result	Possible Causes and Countermeasures	 Page
Is the power supply voltage low?	Yes	The power supply voltage is out of the specifications. Use a voltage that is within the specified operating range.	-
Is the voltage range selection switch for the input power supply set correctly?	No	Set the voltage range selection switch for the input power supply to the correct setting.	2-8

Appx.

The input current is unstable or oscillation occurs.

What to Check	Result	Possible Causes and Countermeasures	 Page
Are there any large loops in the load wiring?	Yes	Rearrange the load wirings. Twist the wires or connect a capacitor to prevent oscillation.	2-6
Is the load wiring long?	Yes		

The calibration can not be performed properly for the total current value (RMS).

What to Check	Result	Possible Causes and Countermeasures	 Page
Is the POWER switch of the slave unit turned off?	Yes	Turn on the POWER switch of the slave unit.	3-31

The error occurs.

What to Check	Result	Possible Causes and Countermeasures	 Page
Is the "xx xxx EPPDATA ERR" displayed on the panel? ("x" may varies depends on the contents of the error)	Yes	The calibration data is changed to the abnormal value due to the internal memory is deteriorated, arrange to have the PCZ1000A repaired.	3-5
	No	Abnormal condition has been occurred in the internal circuit. Immediately stop using the PCZ1000A and arrange for it to be repaired.	-



Index

Program messages

CCRP 4-7
ALMCLR 4-7
CCRP? 4-7
CF 4-7
CF? 4-7
CFSET 4-7
CFSET? 4-7
CRRANGE 4-7
CRRANGE? 4-7
CTRLZ 4-8
CURP? 4-7
CURR? 4-7
ERR? 4-8
FAU? 4-8
FAU2? 4-8
HEAD 4-8
HEAD? 4-8
IDN? 4-8
ISET 4-7
ISET? 4-7
LLO 4-8
LLO? 4-8
LOAD 4-7
LOAD? 4-7
PSET 4-7
PSET? 4-7
RSET 4-7
RSET? 4-7
RST 4-8
SYSCON? 4-7
VOLT? 4-7
XOFF 4-8
XON 4-8

A

accessories 2-2

B

break signal 4-3

C

calibration 3-21, 3-26, 3-30, 5-3
communication settings 4-8
constant current
mode 3-11
constant power
mode 3-15
constant power mode 3-15

constant resistance
mode 3-12
constant-current
mode 3-10, 6-2, A-4
constant-power
mode 3-10, 6-2, A-6
constant-resistance
mode 3-10, 6-2, A-5
crest factor
function 3-16, A-3
machine 3-10
current
limit value 3-17
current waveform 2-10, 2-11, 3-16, A-3

D

dust filter 5-2

E

electrical specifications 6-2
error A-8

F

factory default settings 3-34
firmware versions 1-2
fuse 3-5, 3-8, 6-3, A-7

G

general specifications 6-4, 6-5
grounding 2-8

H

H range 3-14, 6-2

L

L range 3-13, 3-14, 6-2
load input terminals 2-9
cover 2-13
louver 5-3

M

maximum input voltage 2-10

O

- operating
 - humidity range 2-3
 - temperature range 2-3
- Options 1-3
- overcurrent protection 3-7
- overpower protection 3-8
- overvoltage 2-10
 - protection 3-8

P

- power
 - limit value 3-15, 3-17
- procedure for turning on the power 3-5
- program
 - (response) data 4-5
 - header 4-5
 - message terminator 4-4
- protocol 4-3

R

- rack mounting option 1-3
- RANGE switch 3-5
- repair A-7
- resistance
 - limit value 3-13, 3-14, 3-17

S

- signal cable for parallel operation 1-3
- storage
 - humidity range 2-3
 - temperature range 2-3

U

- use in a flammable atmosphere 2-2

V

- voltage range selection switch
 - for the input power supply A-7

